

Digital Inverter 4series 8-10HP

Engineering Data Book

Outdoor Unit

RAV-SM2244AT8(Z)(ZG)-E

RAV-SM2804AT8(Z)(ZG)-E

RAV-SM2244AT7(Z)(ZG)

RAV-SM2804AT7(Z)(ZG)



Contents

1	Specifications	
	<Twin type>	2
	<Triple type>	5
	<Double twin type>	9
2	Construction views (External views)	16
3	Gravity position	17
4	Wiring diagram	18
5	Outdoor Unit refrigerating cycle diagram	19
6	Sensible capacity table	20
7	Part Load Performance	25
8	Sound Characteristics (NC Curve)	35
9	Capacity Correction	36
10	Line up	39
11	Existing Piping	41

1 Specifications

1-1. Indoor Unit

1-1-1. Indoor unit (4-way Cassette Type)

<Twin type>

Model	Indoor unit 1		RAV-SM1104UT-E	RAV-SM1404UT-E	RAV-SM1104UT-E	RAV-SM1404UT-E	
	Indoor unit 2		RAV-SM1104UT-E	RAV-SM1404UT-E	RAV-SM1104UT-E	RAV-SM1404UT-E	
	Outdoor unit		RAV-SM2244AT8-E	RAV-SM2804AT8-E	RAV-SM2244AT7	RAV-SM2804AT7	
Cooling capacity (min. - max.)		(kW)	20.0 (9.8-22.4)	23.0 (9.8-27.0)	20.0 (9.8-22.4)	23.0 (9.8-27.0)	
Heating capacity (min. - max.)		(kW)	22.4 (9.8-25.0)	27.0 (9.8-31.5)	22.4 (9.8-25.0)	27.0 (9.8-31.5)	
Power supply			3 phase 380-415V 50Hz		3 phase 380V 60Hz		
Indoor unit							
Electrical characteristics	Cooling	Running current	(A)	10.09 - 9.24	13.24 - 12.12	10.09	13.24
		Power consumption (min. - max.)	(kW)	6.24 (2.30-8.13)	8.19 (2.30-11.70)	6.24 (2.30-8.13)	8.19 (2.30-11.70)
		Power factor	(%)	94	94	94	94
		EER		3.21	2.81	3.21	2.81
		Energy efficiency class *		A	C	A	C
	Heating	Running current	(A)	9.41 - 8.61	12.09 - 11.07	9.41	12.09
		Power consumption (min. - max.)	(kW)	5.82 (1.90-6.78)	7.48 (1.90-10.34)	5.82 (1.90-6.78)	7.48 (1.90-10.34)
		Power factor	(%)	94	94	94	94
		COP		3.85	3.61	3.85	3.61
		Energy efficiency class *		A	A	A	A
Maximum current		(A)	18	22	18	22	
Fan unit	Fan			Turbo fan	Turbo fan	Turbo fan	Turbo fan
	Standard air flow	H/M/L (m3/min)	33.5/24.0/19.5	35.0/24.0/20.5	33.5/24.0/19.5	35.0/24.0/20.5	
	Motor		(W)	68	72	68	72
Sound pressure level		H/M/L (dB/A)	43/38/33	44/38/34	43/38/33	44/38/34	
Sound power level		H/M/L (dB/A)	58/53/48	59/53/49	58/53/48	59/53/49	
Outdoor unit							
Outer dimension	Max. total length		(m)	70	70	70	70
	Min. length		(m)	7.5	7.5	7.5	7.5
	Height difference	Outdoor lower	(m)	30	30	30	30
		Outdoor high	(m)	30	30	30	30
Fan unit	Fan			Propeller fan	Propeller fan	Propeller fan	Propeller fan
	Standard air flow high		(m3/min)	133	133	133	133
	Motor		(W)	100 + 100	100 + 100	100 + 100	100 + 100
Connecting pipe	Outdoor unit - Pipe branch	Gas side	(mm)	28.6	28.6	28.6	28.6
		Liquid side	(mm)	12.7	12.7	12.7	12.7
	Pipe branch - Indoor unit	Gas side	(mm)	15.9	15.9	15.9	15.9
		Liquid side	(mm)	9.5	9.5	9.5	9.5
Sound pressure level		Cooling/Heating (dB/A)	56/57	57/58	56/57	57/58	
Sound power level		Cooling/Heating (dB/A)	72/74	74/75	72/74	74/75	

* IEC standard

1-1-2. Indoor unit (Duct Type)

<Twin type>

Model		Indoor unit 1		RAV-SM1102BT-E	RAV-SM1402BT-E	RAV-SM1102BT-E	RAV-SM1402BT-E
		Indoor unit 2		RAV-SM1102BT-E	RAV-SM1402BT-E	RAV-SM1102BT-E	RAV-SM1402BT-E
		Outdoor unit		RAV-SM2244AT8-E	RAV-SM2804AT8-E	RAV-SM2244AT7	RAV-SM2804AT7
Cooling capacity (min. - max.)		(kW)	20.0 (9.8-22.4)	23.0 (9.8-27.0)	20.0 (9.8-22.4)	23.0 (9.8-27.0)	
Heating capacity (min. - max.)		(kW)	22.4 (9.8-25.0)	27.0 (9.8-31.5)	22.4 (9.8-25.0)	27.0 (9.8-31.5)	
Power supply			3 phase 380-415V 50Hz		3 phase 380V 60Hz		
Indoor unit							
Electrical characteristics	Cooling	Running current (A)		11.51 - 10.54	15.44 - 14.13	11.51	15.44
		Power consumption (min. - max.) (kW)		7.12 (2.37-9.28)	9.55 (2.37-13.39)	7.12 (2.37-9.28)	9.55 (2.37-13.39)
		Power factor (%)		94	94	94	94
		EER		2.81	2.41	2.81	2.41
		Energy efficiency class *		C	E	C	E
	Heating	Running current (A)		10.34 - 9.47	12.80 - 11.72	10.34	12.80
		Power consumption (min. - max.) (kW)		6.40 (1.98-7.46)	7.92 (1.98-10.95)	6.40 (1.98-7.46)	7.92 (1.98-10.95)
		Power factor (%)		94	94	94	94
		COP		3.50	3.41	3.50	3.41
		Energy efficiency class *		B	B	B	B
Maximum current (A)		18	22	18	22		
Fan unit	Fan		Centrifugal		Centrifugal	Centrifugal	Centrifugal
	Standard air flow	H/M/L (m3/min)	27.0/23.0/18.9	33.0/28.0/23.1	27.0/23.0/18.9	33.0/28.0/23.1	
	Motor (W)		120	120	120	120	
Sound pressure level		H/M/L (dB/A)	42/39/36	44/41/38	42/39/36	44/41/38	
Sound power level		H/M/L (dB/A)	57/54/51	59/56/53	57/54/51	59/56/53	
Outdoor unit							
Outer dimension	Max. total length (m)		70	70	70	70	
	Min. length (m)		7.5	7.5	7.5	7.5	
	Height difference	Outdoor lower (m)	30	30	30	30	
		Outdoor high (m)	30	30	30	30	
Fan unit	Fan		Propeller fan		Propeller fan	Propeller fan	Propeller fan
	Standard air flow high (m3/min)		133	133	133	133	
	Motor (W)		100 + 100	100 + 100	100 + 100	100 + 100	
Connecting pipe	Outdoor unit - Pipe branch		Gas side (mm)	28.6	28.6	28.6	28.6
			Liquid side (mm)	12.7	12.7	12.7	12.7
	Pipe branch - Indoor unit		Gas side (mm)	15.9	15.9	15.9	15.9
			Liquid side (mm)	9.5	9.5	9.5	9.5
Sound pressure level		Cooling/Heating (dB/A)	56/57	57/58	56/57	57/58	
Sound power level		Cooling/Heating (dB/A)	72/74	74/75	72/74	74/75	

* IEC standard

1-1-3. Indoor unit (Ceiling Type)

<Twin type>

Model		Indoor unit 1		RAV-SM1102CT-E	RAV-SM1402CT-E	RAV-SM1102CT-E	RAV-SM1402CT-E
		Indoor unit 2		RAV-SM1102CT-E	RAV-SM1402CT-E	RAV-SM1102CT-E	RAV-SM1402CT-E
		Outdoor unit		RAV-SM2244AT8-E	RAV-SM2804AT8-E	RAV-SM2244AT7	RAV-SM2804AT7
Cooling capacity (min. - max.)		(kW)	20.0 (9.8-22.4)	23.0 (9.8-27.0)	20.0 (9.8-22.4)	23.0 (9.8-27.0)	
Heating capacity (min. - max.)		(kW)	22.4 (9.8-25.0)	27.0 (9.8-31.5)	22.4 (9.8-25.0)	27.0 (9.8-31.5)	
Power supply			3 phase 380-415V 50Hz		3 phase 380V 60Hz		
Indoor unit							
Electrical characteristics	Cooling	Running current (A)		11.51 - 10.54	15.44 - 14.13	11.51	15.44
		Power consumption (min. - max.) (kW)		7.12 (2.37-9.28)	9.55 (2.37-13.39)	7.12 (2.37-9.28)	9.55 (2.37-13.39)
		Power factor (%)		94	94	94	94
		EER		2.81	2.41	2.81	2.41
		Energy efficiency class *		C	E	C	E
	Heating	Running current (A)		10.34 - 9.47	12.80 - 11.72	10.34	12.80
		Power consumption (min. - max.) (kW)		6.40 (1.98-7.46)	7.92 (1.98-10.95)	6.40 (1.98-7.46)	7.92 (1.98-10.95)
		Power factor (%)		94	94	94	94
		COP		3.50	3.41	3.50	3.41
		Energy efficiency class *		B	B	B	B
Maximum current (A)		18	22	18	22		
Fan unit	Fan		Centrifugal		Centrifugal	Centrifugal	Centrifugal
	Standard air flow	H/M/L (m3/min)	27.5/24.0/21.2	30.0/26.0/23.1	27.5/24.0/21.2	30.0/26.0/23.1	
	Motor (W)		120	120	120	120	
Sound pressure level		H/M/L (dB/A)	41/38/35	43/40/37	41/38/35	43/40/37	
Sound power level		H/M/L (dB/A)	56/53/50	58/55/52	56/53/50	58/55/52	
Outdoor unit							
Outer dimension	Max. total length (m)		70	70	70	70	
	Min. length (m)		7.5	7.5	7.5	7.5	
	Height difference	Outdoor lower (m)	30	30	30	30	
		Outdoor high (m)	30	30	30	30	
Fan unit	Fan		Propeller fan		Propeller fan	Propeller fan	Propeller fan
	Standard air flow high (m3/min)		133	133	133	133	
	Motor (W)		100 + 100	100 + 100	100 + 100	100 + 100	
Connecting pipe	Outdoor unit - Pipe branch		Gas side (mm)	28.6	28.6	28.6	28.6
			Liquid side (mm)	12.7	12.7	12.7	12.7
	Pipe branch - Indoor unit		Gas side (mm)	15.9	15.9	15.9	15.9
			Liquid side (mm)	9.5	9.5	9.5	9.5
Sound pressure level		Cooling/Heating (dB/A)	56/57	57/58	56/57	57/58	
Sound power level		Cooling/Heating (dB/A)	72/74	74/75	72/74	74/75	

* IEC standard

1-1-4. Indoor unit (4-way Cassette Type)

<Triple type>

Model		Indoor unit 1		RAV-SM804UT-E	RAV-SM804UT-E	RAV-SM804UT-E	RAV-SM804UT-E	
		Indoor unit 2		RAV-SM804UT-E	RAV-SM804UT-E	RAV-SM804UT-E	RAV-SM804UT-E	
		Indoor unit 3		RAV-SM804UT-E	RAV-SM804UT-E	RAV-SM804UT-E	RAV-SM804UT-E	
		Outdoor unit		RAV-SM2244AT8-E	RAV-SM2804AT8-E	RAV-SM2244AT7	RAV-SM2804AT7	
Cooling capacity (min. - max.)		(kW)	20.0 (9.8-22.4)	23.0 (9.8-27.0)	20.0 (9.8-22.4)	23.0 (9.8-27.0)		
Heating capacity (min. - max.)		(kW)	22.4 (9.8-25.0)	27.0 (9.8-31.5)	22.4 (9.8-25.0)	27.0 (9.8-31.5)		
Power supply			3 phase 380-415V 50Hz		3 phase 380V 60Hz			
Indoor unit								
Electrical characteristics	Cooling	Running current		(A)	11.51 - 10.54	15.44 - 14.13	11.51	15.44
		Power consumption (min. - max.)		(kW)	6.24 (2.30-8.13)	8.19 (2.30-11.70)	6.24 (2.30-8.13)	8.19 (2.30-11.70)
		Power factor		(%)	94	94	94	94
		EER			3.21	2.81	3.21	2.81
		Energy efficiency class *			A	C	A	C
	Heating	Running current		(A)	10.34 - 9.47	12.80 - 11.72	10.34	12.80
		Power consumption (min. - max.)		(kW)	5.82 (1.90-6.78)	7.48 (1.90-10.34)	5.82 (1.90-6.78)	7.48 (1.90-10.34)
		Power factor		(%)	94	94	94	94
		COP			3.85	3.61	3.85	3.61
		Energy efficiency class *			A	A	A	A
Maximum current		(A)	18	22	18	22		
Fan unit	Fan			Turbo fan	Turbo fan	Turbo fan	Turbo fan	
	Standard air flow	H/M/L (m3/min)	20.5/16.0/13.5	20.5/16.0/13.5	20.5/16.0/13.5	20.5/16.0/13.5		
	Motor		(W)	20	20	20	20	
Sound pressure level		H/M/L (dB/A)	35/31/28	35/31/28	35/31/28	35/31/28		
Sound power level		H/M/L (dB/A)	50/46/43	50/46/43	50/46/43	50/46/43		
Outdoor unit								
Outer dimension	Max. total length		(m)	70	70	70	70	
	Min. length		(m)	7.5	7.5	7.5	7.5	
	Height difference	Outdoor lower	(m)	30	30	30	30	
		Outdoor high	(m)	30	30	30	30	
Fan unit	Fan			Propeller fan	Propeller fan	Propeller fan	Propeller fan	
	Standard air flow high		(m3/min)	133	133	133	133	
	Motor		(W)	100 + 100	100 + 100	100 + 100	100 + 100	
Connecting pipe	Outdoor unit - Pipe branch		Gas side	(mm)	28.6	28.6	28.6	28.6
			Liquid side	(mm)	12.7	12.7	12.7	12.7
	Pipe branch - Indoor unit		Gas side	(mm)	15.9	15.9	15.9	15.9
			Liquid side	(mm)	9.5	9.5	9.5	9.5
Sound pressure level		Cooling/Heating (dB/A)	56/57	57/58	56/57	57/58		
Sound power level		Cooling/Heating (dB/A)	72/74	74/75	72/74	74/75		

* IEC standard

1-1-5. Indoor unit (Duct Type)

<Triple type>

Model		Indoor unit 1		RAV-SM802BT-E	RAV-SM802BT-E	RAV-SM802BT-E	RAV-SM802BT-E	
		Indoor unit 2		RAV-SM802BT-E	RAV-SM802BT-E	RAV-SM802BT-E	RAV-SM802BT-E	
		Indoor unit 3		RAV-SM802BT-E	RAV-SM802BT-E	RAV-SM802BT-E	RAV-SM802BT-E	
		Outdoor unit		RAV-SM2244AT8-E	RAV-SM2804AT8-E	RAV-SM2244AT7	RAV-SM2804AT7	
Cooling capacity (min. - max.)		(kW)	20.0 (9.8-22.4)	23.0 (9.8-27.0)	20.0 (9.8-22.4)	23.0 (9.8-27.0)		
Heating capacity (min. - max.)		(kW)	22.4 (9.8-25.0)	27.0 (9.8-31.5)	22.4 (9.8-25.0)	27.0 (9.8-31.5)		
Power supply			3 phase 380-415V 50Hz		3 phase 380V 60Hz			
Indoor unit								
Electrical characteristics	Cooling	Running current		(A)	11.51 - 10.54	15.44 - 14.13	11.51	15.44
		Power consumption (min. - max.)		(kW)	7.12 (2.37-9.28)	9.55 (2.37-13.39)	7.12 (2.37-9.28)	9.55 (2.37-13.39)
		Power factor		(%)	94	94	94	94
		EER			2.81	2.41	2.81	2.41
		Energy efficiency class *			C	E	C	E
	Heating	Running current		(A)	10.34 - 9.47	12.80 - 11.72	10.34	12.80
		Power consumption (min. - max.)		(kW)	6.40 (1.98-7.46)	7.92 (1.98-10.95)	6.40 (1.98-7.46)	7.92 (1.98-10.95)
		Power factor		(%)	94	94	94	94
		COP			3.50	3.41	3.50	3.41
		Energy efficiency class *			B	B	B	B
Maximum current		(A)	18	22	18	22		
Fan unit	Fan			Centrifugal	Centrifugal	Centrifugal	Centrifugal	
	Standard air flow	H/M/L (m3/min)	19.0/16.2/13.3	19.0/16.2/13.3	19.0/16.2/13.3	19.0/16.2/13.3		
	Motor		(W)	120	120	120	120	
Sound pressure level		H/M/L (dB/A)	40/37/34	40/37/34	40/37/34	40/37/34		
Sound power level		H/M/L (dB/A)	55/52/49	55/52/49	55/52/49	55/52/49		
Outdoor unit								
Outer dimension	Max. total length		(m)	70	70	70	70	
	Min. length		(m)	7.5	7.5	7.5	7.5	
	Height difference	Outdoor lower	(m)	30	30	30	30	
		Outdoor high	(m)	30	30	30	30	
Fan unit	Fan			Propeller fan	Propeller fan	Propeller fan	Propeller fan	
	Standard air flow high		(m3/min)	133	133	133	133	
	Motor		(W)	100 + 100	100 + 100	100 + 100	100 + 100	
Connecting pipe	Outdoor unit - Pipe branch		Gas side	(mm)	28.6	28.6	28.6	28.6
			Liquid side	(mm)	12.7	12.7	12.7	12.7
	Pipe branch - Indoor unit		Gas side	(mm)	15.9	15.9	15.9	15.9
			Liquid side	(mm)	9.5	9.5	9.5	9.5
Sound pressure level	Cooling/Heating		(dB/A)	56/57	57/58	56/57	57/58	
Sound power level	Cooling/Heating		(dB/A)	72/74	74/75	72/74	74/75	

* IEC standard

1-1-6. Indoor unit (Ceiling Type)

<Triple type>

Model		Indoor unit 1		RAV-SM802CT-E	RAV-SM802CT-E	RAV-SM802CT-E	RAV-SM802CT-E	
		Indoor unit 2		RAV-SM802CT-E	RAV-SM802CT-E	RAV-SM802CT-E	RAV-SM802CT-E	
		Indoor unit 3		RAV-SM802CT-E	RAV-SM802CT-E	RAV-SM802CT-E	RAV-SM802CT-E	
		Outdoor unit		RAV-SM2244AT8-E	RAV-SM2804AT8-E	RAV-SM2244AT7	RAV-SM2804AT7	
Cooling capacity (min. - max.)		(kW)	20.0 (9.8-22.4)	23.0 (9.8-27.0)	20.0 (9.8-22.4)	23.0 (9.8-27.0)		
Heating capacity (min. - max.)		(kW)	22.4 (9.8-25.0)	27.0 (9.8-31.5)	22.4 (9.8-25.0)	27.0 (9.8-31.5)		
Power supply			3 phase 380-415V 50Hz		3 phase 380V 60Hz			
Indoor unit								
Electrical characteristics	Cooling	Running current		(A)	11.51 - 10.54	15.44 - 14.13	11.51	15.44
		Power consumption (min. - max.)		(kW)	7.12 (2.37-9.28)	9.55 (2.37-13.39)	7.12 (2.37-9.28)	9.55 (2.37-13.39)
		Power factor		(%)	94	94	94	94
		EER			2.81	2.41	2.81	2.41
		Energy efficiency class *			C	E	C	E
	Heating	Running current		(A)	10.34 - 9.47	12.80 - 11.72	10.34	12.80
		Power consumption (min. - max.)		(kW)	6.40 (1.98-7.46)	7.92 (1.98-10.95)	6.40 (1.98-7.46)	7.92 (1.98-10.95)
		Power factor		(%)	94	94	94	94
		COP			3.50	3.41	3.50	3.41
		Energy efficiency class *			B	B	B	B
Maximum current		(A)	18	22	18	22		
Fan unit	Fan			Centrifugal	Centrifugal	Centrifugal	Centrifugal	
	Standard air flow	H/M/L (m3/min)	18.5/16.7/14.6	18.5/16.7/14.6	18.5/16.7/14.6	18.5/16.7/14.6		
	Motor		(W)	60	60	60	60	
Sound pressure level		H/M/L (dB/A)	38/36/33	38/36/33	38/36/33	38/36/33		
Sound power level		H/M/L (dB/A)	53/51/48	53/51/48	53/51/48	53/51/48		
Outdoor unit								
Outer dimension	Max. total length		(m)	70	70	70	70	
	Min. length		(m)	7.5	7.5	7.5	7.5	
	Height difference	Outdoor lower	(m)	30	30	30	30	
		Outdoor high	(m)	30	30	30	30	
Fan unit	Fan			Propeller fan	Propeller fan	Propeller fan	Propeller fan	
	Standard air flow high		(m3/min)	133	133	133	133	
	Motor		(W)	100 + 100	100 + 100	100 + 100	100 + 100	
Connecting pipe	Outdoor unit - Pipe branch		Gas side	(mm)	28.6	28.6	28.6	
			Liquid side	(mm)	12.7	12.7	12.7	
	Pipe branch - Indoor unit		Gas side	(mm)	15.9	15.9	15.9	
			Liquid side	(mm)	9.5	9.5	9.5	
Sound pressure level	Cooling/Heating		(dB/A)	56/57	57/58	56/57	57/58	
Sound power level	Cooling/Heating		(dB/A)	72/74	74/75	72/74	74/75	

* IEC standard

1-1-7. Indoor unit (High wall Type)

<Triple type>

Model		Indoor unit 1		RAV-SM802KRT-E	RAV-SM802KRT-E	RAV-SM802KRT-E	RAV-SM802KRT-E	
		Indoor unit 2		RAV-SM802KRT-E	RAV-SM802KRT-E	RAV-SM802KRT-E	RAV-SM802KRT-E	
		Indoor unit 3		RAV-SM802KRT-E	RAV-SM802KRT-E	RAV-SM802KRT-E	RAV-SM802KRT-E	
		Outdoor unit		RAV-SM2244AT8-E	RAV-SM2804AT8-E	RAV-SM2244AT7	RAV-SM2804AT7	
Cooling capacity (min. - max.)		(kW)	20.0 (9.8-22.4)	23.0 (9.8-27.0)	20.0 (9.8-22.4)	23.0 (9.8-27.0)		
Heating capacity (min. - max.)		(kW)	22.4 (9.8-25.0)	27.0 (9.8-31.5)	22.4 (9.8-25.0)	27.0 (9.8-31.5)		
Power supply			3 phase 380-415V 50Hz		3 phase 380V 60Hz			
Indoor unit								
Electrical characteristics	Cooling	Running current		(A)	11.51 - 10.54	15.44 - 14.13	11.51	15.44
		Power consumption (min. - max.)		(kW)	7.12 (2.37-9.28)	9.55 (2.37-13.39)	7.12 (2.37-9.28)	9.55 (2.37-13.39)
		Power factor		(%)	94	94	94	94
		EER			2.81	2.41	2.81	2.41
		Energy efficiency class *			C	E	C	E
	Heating	Running current		(A)	10.34 - 9.47	12.80 - 11.72	10.34	12.80
		Power consumption (min. - max.)		(kW)	6.40 (1.98-7.46)	7.92 (1.98-10.95)	6.40 (1.98-7.46)	7.92 (1.98-10.95)
		Power factor		(%)	94	94	94	94
		COP			3.50	3.41	3.50	3.41
		Energy efficiency class *			B	B	B	B
Maximum current		(A)	18	22	18	22		
Fan unit	Fan			Cross flow fan	Cross flow fan	Cross flow fan	Cross flow fan	
	Standard air flow	H/M/L (m3/min)	18.5/14.6/12.2	18.5/14.6/12.2	18.5/14.6/12.2	18.5/14.6/12.2		
	Motor		(W)	30	30	30	30	
Sound pressure level		H/M/L (dB/A)	45/41/36	45/41/36	45/41/36	45/41/36		
Sound power level		H/M/L (dB/A)	60/56/51	60/56/51	60/56/51	60/56/51		
Outdoor unit								
Outer dimension	Max. total length		(m)	70	70	70	70	
	Min. length		(m)	7.5	7.5	7.5	7.5	
	Height difference	Outdoor lower	(m)	30	30	30	30	
		Outdoor high	(m)	30	30	30	30	
Fan unit	Fan			Propeller fan	Propeller fan	Propeller fan	Propeller fan	
	Standard air flow high		(m3/min)	133	133	133	133	
	Motor		(W)	100 + 100	100 + 100	100 + 100	100 + 100	
Connecting pipe	Outdoor unit - Pipe branch		Gas side	(mm)	28.6	28.6	28.6	28.6
			Liquid side	(mm)	12.7	12.7	12.7	12.7
	Pipe branch - Indoor unit		Gas side	(mm)	15.9	15.9	15.9	15.9
			Liquid side	(mm)	9.5	9.5	9.5	9.5
Sound pressure level		Cooling/Heating (dB/A)	56/57	57/58	56/57	57/58		
Sound power level		Cooling/Heating (dB/A)	72/74	74/75	72/74	74/75		

* IEC standard

1-1-8. Indoor unit (4-way Cassette Type)

<Double twin type>

Model		Indoor unit 1		RAV-SM564UT-E	RAV-SM804UT-E	RAV-SM564UT-E	RAV-SM804UT-E
		Indoor unit 2		RAV-SM564UT-E	RAV-SM804UT-E	RAV-SM564UT-E	RAV-SM804UT-E
		Indoor unit 3		RAV-SM564UT-E	RAV-SM804UT-E	RAV-SM564UT-E	RAV-SM804UT-E
		Indoor unit 4		RAV-SM564UT-E	RAV-SM804UT-E	RAV-SM564UT-E	RAV-SM804UT-E
		Outdoor unit		RAV-SM2244AT8-E	RAV-SM2804AT8-E	RAV-SM2244AT7	RAV-SM2804AT7
Cooling capacity (min. - max.)		(kW)	20.0 (9.8-22.4)	23.0 (9.8-27.0)	20.0 (9.8-22.4)	23.0 (9.8-27.0)	
Heating capacity (min. - max.)		(kW)	22.4 (9.8-25.0)	27.0 (9.8-31.5)	22.4 (9.8-25.0)	27.0 (9.8-31.5)	
Power supply			3 phase 380-415V 50Hz		3 phase 380V 60Hz		
Indoor unit							
Electrical characteristics	Cooling	Running current (A)		10.09 - 9.24	13.24 - 12.12	10.09	13.24
		Power consumption (min. - max.) (kW)		6.24 (2.30-8.13)	8.19 (2.30-11.70)	6.24 (2.30-8.13)	8.19 (2.30-11.70)
		Power factor (%)		94	94	94	94
		EER		3.21	2.81	3.21	2.81
		Energy efficiency class *		A	C	A	C
	Heating	Running current (A)		9.41 - 8.61	12.09 - 11.07	9.41	12.09
		Power consumption (min. - max.) (kW)		5.82 (1.90-6.78)	7.76 (1.90-10.34)	5.82 (1.90-6.78)	7.76 (1.90-10.34)
		Power factor (%)		94	94	94	94
		COP		3.85	3.48	3.85	3.48
		Energy efficiency class *		A	B	A	B
Maximum current (A)		18	22	18	22		
Fan unit	Fan		Turbo fan	Turbo fan	Turbo fan	Turbo fan	
	Standard air flow	H/M/L (m3/min)	17.5/14.5/13.0	20.5/16.0/13.5	17.5/14.5/13.0	20.5/16.0/13.5	
	Motor (W)		14	20	14	20	
Sound pressure level		H/M/L (dB/A)	32/29/28	35/31/28	32/29/28	35/31/28	
Sound power level		H/M/L (dB/A)	47/44/43	50/46/43	47/44/43	50/46/43	
Outdoor unit							
Outer dimension	Max. total length (m)		70	70	70	70	
	Min. length (m)		7.5	7.5	7.5	7.5	
	Height difference	Outdoor lower (m)	30	30	30	30	
		Outdoor high (m)	30	30	30	30	
Fan unit	Fan		Propeller fan	Propeller fan	Propeller fan	Propeller fan	
	Standard air flow high (m3/min)		133	133	133	133	
	Motor (W)		100 + 100	100 + 100	100 + 100	100 + 100	
Connecting pipe	Outdoor unit - First pipe branch	Gas side (mm)	28.6	28.6	28.6	28.6	
		Liquid side (mm)	12.7	12.7	12.7	12.7	
	First pipe branch - Second pipe branch	Gas side (mm)	15.9	15.9	15.9	15.9	
		Liquid side (mm)	9.5	9.5	9.5	9.5	
	Second pipe branch - Indoor unit	Gas side (mm)	12.7	15.9	12.7	15.9	
		Liquid side (mm)	6.4	9.5	6.4	9.5	
Sound pressure level		Cooling/Heating (dB/A)	56/57	57/58	56/57	57/58	
Sound power level		Cooling/Heating (dB/A)	72/74	74/75	72/74	74/75	

* IEC standard

1-1-9. Indoor unit (Compact 4-way Cassette (600 × 600) Type)

<Double twin type>

Model	Indoor unit 1		RAV-SM562MUT-E	RAV-SM562MUT-E	
	Indoor unit 2		RAV-SM562MUT-E	RAV-SM562MUT-E	
	Indoor unit 3		RAV-SM562MUT-E	RAV-SM562MUT-E	
	Indoor unit 4		RAV-SM562MUT-E	RAV-SM562MUT-E	
	Outdoor unit		RAV-SM2244AT8-E	RAV-SM2244AT7	
Cooling capacity (min. - max.)		(kW)	20.0 (9.8-22.4)	20.0 (9.8-22.4)	
Heating capacity (min. - max.)		(kW)	22.4 (9.8-25.0)	22.4 (9.8-25.0)	
Power supply			3 phase 380-415V 50Hz	3 phase 380V 60Hz	
Indoor unit					
Electrical characteristics	Cooling	Running current (A)		11.51 - 10.54	11.51
		Power consumption (min. - max.) (kW)		7.12 (2.37-9.28)	7.12 (2.37-9.28)
		Power factor (%)		94	94
		EER		2.81	2.81
		Energy efficiency class *		C	C
	Heating	Running current (A)		10.34 - 9.47	10.34
		Power consumption (min. - max.) (kW)		6.40 (1.98-7.46)	6.40 (1.98-7.46)
		Power factor (%)		94	94
		COP		3.50	3.50
		Energy efficiency class *		B	B
Maximum current (A)			18	18	
Fan unit	Fan		Turbo fan	Turbo fan	
	Standard air flow	H/M/L (m3/min)	13.3/11.2/9.1	13.3/11.2/9.1	
	Motor (W)		60	60	
Sound pressure level		H/M/L (dB/A)	43/39/34	43/39/34	
Sound power level		H/M/L (dB/A)	58/54/49	58/54/49	
Outdoor unit					
Outer dimension	Max. total length (m)		70	70	
	Min. length (m)		7.5	7.5	
	Height difference	Outdoor lower (m)	30	30	
		Outdoor high (m)	30	30	
Fan unit	Fan		Propeller fan	Propeller fan	
	Standard air flow high (m3/min)		133	133	
	Motor (W)		100 + 100	100 + 100	
Connecting pipe	Outdoor unit - First pipe branch	Gas side (mm)	28.6	28.6	
		Liquid side (mm)	12.7	12.7	
	First pipe branch - Second pipe branch	Gas side (mm)	15.9	15.9	
		Liquid side (mm)	9.5	9.5	
	Second pipe branch - Indoor unit	Gas side (mm)	12.7	12.7	
		Liquid side (mm)	6.4	6.4	
Sound pressure level		Cooling/Heating (dB/A)	56/57	56/57	
Sound power level		Cooling/Heating (dB/A)	72/74	72/74	

* IEC standard

1-1-10. Indoor unit (Slim Duct Type)

<Double twin type>

Model		Indoor unit 1		RAV-SM564SDT-E	RAV-SM564SDT-E	
		Indoor unit 2		RAV-SM564SDT-E	RAV-SM564SDT-E	
		Indoor unit 3		RAV-SM564SDT-E	RAV-SM564SDT-E	
		Indoor unit 4		RAV-SM564SDT-E	RAV-SM564SDT-E	
		Outdoor unit		RAV-SM2244AT8-E	RAV-SM2244AT7	
Cooling capacity (min. - max.)		(kW)	20.0 (9.8-22.4)	20.0 (9.8-22.4)		
Heating capacity (min. - max.)		(kW)	22.4 (9.8-25.0)	22.4 (9.8-25.0)		
Power supply			3 phase 380-415V 50Hz	3 phase 380V 60Hz		
Indoor unit						
Electrical characteristics	Cooling	Running current		(A)	11.51 - 10.54	11.51
		Power consumption (min. - max.)		(kW)	7.12 (2.37-9.28)	7.12 (2.37-9.28)
		Power factor		(%)	94	94
		EER			2.81	2.81
		Energy efficiency class *			C	C
	Heating	Running current		(A)	10.34 - 9.47	10.34
		Power consumption (min. - max.)		(kW)	6.40 (1.98-7.46)	6.40 (1.98-7.46)
		Power factor		(%)	94	94
		COP			3.50	3.50
		Energy efficiency class *			B	B
Maximum current		(A)	18	18		
Fan unit	Fan			Centrifugal fan	Centrifugal fan	
	Standard air flow	H/M/L	(m3/min)	13.0/11.3/9.7	13.0/11.3/9.7	
	Motor		(W)	60	60	
	External static pressure	Standard (at shipment)		(Pa)	10	10
		Set up for tap exchange		(Pa)	10/20/35/50	10/20/35/50
Sound pressure level	Under air inlet	H/M/L	(dB/A)	45/40/36	45/40/36	
	Back air inlet	H/M/L	(dB/A)	33/31/28	33/31/28	
Sound power level	Under air inlet	H/M/L	(dB/A)	60/55/51	60/55/51	
	Back air inlet	H/M/L	(dB/A)	48/46/43	48/46/43	
Outdoor unit						
Outer dimension	Max. total length		(m)	70	70	
	Min. length		(m)	7.5	7.5	
	Height difference	Outdoor lower		(m)	30	30
		Outdoor high		(m)	30	30
Fan unit	Fan			Propeller fan	Propeller fan	
	Standard air flow high		(m3/min)	133	133	
	Motor		(W)	100 + 100	100 + 100	
Connecting pipe	Outdoor unit - First pipe branch		Gas side	(mm)	28.6	28.6
			Liquid side	(mm)	12.7	12.7
	First pipe branch - Second pipe branch		Gas side	(mm)	15.9	15.9
			Liquid side	(mm)	9.5	9.5
	Second pipe branch - Indoor unit		Gas side	(mm)	12.7	12.7
			Liquid side	(mm)	6.4	6.4
Sound pressure level	Cooling/Heating		(dB/A)	56/57	56/57	
Sound power level	Cooling/Heating		(dB/A)	72/74	72/74	

* IEC standard

1-1-11. Indoor unit (Duct Type)

<Double twin type>

Model	Indoor unit 1		RAV-SM562BT-E	RAV-SM802BT-E	RAV-SM562BT-E	RAV-SM802BT-E	
	Indoor unit 2		RAV-SM562BT-E	RAV-SM802BT-E	RAV-SM562BT-E	RAV-SM802BT-E	
	Indoor unit 3		RAV-SM562BT-E	RAV-SM802BT-E	RAV-SM562BT-E	RAV-SM802BT-E	
	Indoor unit 4		RAV-SM562BT-E	RAV-SM802BT-E	RAV-SM562BT-E	RAV-SM802BT-E	
	Outdoor unit		RAV-SM2244AT8-E	RAV-SM2804AT8-E	RAV-SM2244AT7	RAV-SM2804AT7	
Cooling capacity (min. - max.)		(kW)	20.0 (9.8-22.4)	23.0 (9.8-27.0)	20.0 (9.8-22.4)	23.0 (9.8-27.0)	
Heating capacity (min. - max.)		(kW)	22.4 (9.8-25.0)	27.0 (9.8-31.5)	22.4 (9.8-25.0)	27.0 (9.8-31.5)	
Power supply			3 phase 380-415V 50Hz		3 phase 380V 60Hz		
Indoor unit							
Electrical characteristics	Cooling	Running current (A)		11.51 - 10.54	15.44 - 14.13	11.51	15.44
		Power consumption (min. - max.) (kW)		7.12 (2.37-9.28)	9.55 (2.37-13.39)	7.12 (2.37-9.28)	9.55 (2.37-13.39)
		Power factor (%)		94	94	94	94
		EER		2.81	2.41	2.81	2.41
		Energy efficiency class *		C	E	C	E
	Heating	Running current (A)		10.34 - 9.47	12.80 - 11.72	10.34	12.80
		Power consumption (min. - max.) (kW)		6.40 (1.98-7.46)	7.92 (1.98-10.95)	6.40 (1.98-7.46)	7.92 (1.98-10.95)
		Power factor (%)		94	94	94	94
		COP		3.50	3.41	3.50	3.41
		Energy efficiency class *		B	B	B	B
Maximum current (A)		18	22	18	22		
Fan unit	Fan		Centrifugal	Centrifugal	Centrifugal	Centrifugal	
	Standard air flow	H/M/L (m3/min)	13.0/11.9/9.8	19.0/16.2/13.3	13.0/11.9/9.8	19.0/16.2/13.3	
	Motor (W)		120	120	120	120	
Sound pressure level		H/M/L (dB/A)	40/37/33	40/37/34	40/37/33	40/37/34	
Sound power level		H/M/L (dB/A)	55/52/48	55/52/49	55/52/48	55/52/49	
Outdoor unit							
Outer dimension	Max. total length (m)		70	70	70	70	
	Min. length (m)		7.5	7.5	7.5	7.5	
	Height difference	Outdoor lower (m)	30	30	30	30	
		Outdoor high (m)	30	30	30	30	
Fan unit	Fan		Propeller fan	Propeller fan	Propeller fan	Propeller fan	
	Standard air flow high	(m3/min)	133	133	133	133	
	Motor (W)		100 + 100	100 + 100	100 + 100	100 + 100	
Connecting pipe	Outdoor unit - First pipe branch	Gas side (mm)	28.6	28.6	28.6	28.6	
		Liquid side (mm)	12.7	12.7	12.7	12.7	
	First pipe branch - Second pipe branch	Gas side (mm)	15.9	15.9	15.9	15.9	
		Liquid side (mm)	9.5	9.5	9.5	9.5	
	Second pipe branch - Indoor unit	Gas side (mm)	12.7	15.9	12.7	15.9	
		Liquid side (mm)	6.4	9.5	6.4	9.5	
Sound pressure level	Cooling/Heating (dB/A)		56/57	57/58	56/57	57/58	
Sound power level	Cooling/Heating (dB/A)		72/74	74/75	72/74	74/75	

* IEC standard

1-1-12. Indoor unit (Ceiling Type)

<Double twin type>

Model		Indoor unit 1		RAV-SM562CT-E	RAV-SM802CT-E	RAV-SM562CT-E	RAV-SM802CT-E
		Indoor unit 2		RAV-SM562CT-E	RAV-SM802CT-E	RAV-SM562CT-E	RAV-SM802CT-E
		Indoor unit 3		RAV-SM562CT-E	RAV-SM802CT-E	RAV-SM562CT-E	RAV-SM802CT-E
		Indoor unit 4		RAV-SM562CT-E	RAV-SM802CT-E	RAV-SM562CT-E	RAV-SM802CT-E
		Outdoor unit		RAV-SM2244AT8-E	RAV-SM2804AT8-E	RAV-SM2244AT7	RAV-SM2804AT7
Cooling capacity (min. - max.)		(kW)	20.0 (9.8-22.4)	23.0 (9.8-27.0)	20.0 (9.8-22.4)	23.0 (9.8-27.0)	
Heating capacity (min. - max.)		(kW)	22.4 (9.8-25.0)	27.0 (9.8-31.5)	22.4 (9.8-25.0)	27.0 (9.8-31.5)	
Power supply			3 phase 380-415V 50Hz		3 phase 380V 60Hz		
Indoor unit							
Electrical characteristics	Cooling	Running current (A)		11.51 - 10.54	15.44 - 14.13	11.51	15.44
		Power consumption (min. - max.) (kW)		7.12 (2.37-9.28)	9.55 (2.37-13.39)	7.12 (2.37-9.28)	9.55 (2.37-13.39)
		Power factor (%)		94	94	94	94
		EER		2.81	2.41	2.81	2.41
		Energy efficiency class *		C	E	C	E
	Heating	Running current (A)		10.34 - 9.47	12.80 - 11.72	10.34	12.80
		Power consumption (min. - max.) (kW)		6.40 (1.98-7.46)	7.92 (1.98-10.95)	6.40 (1.98-7.46)	7.92 (1.98-10.95)
		Power factor (%)		94	94	94	94
		COP		3.50	3.41	3.50	3.41
		Energy efficiency class *		B	B	B	B
Maximum current (A)		18	22	18	22		
Fan unit	Fan		Centrifugal	Centrifugal	Centrifugal	Centrifugal	
	Standard air flow	H/M/L (m3/min)	13.0/11.2/10.0	18.5/16.7/14.6	13.0/11.2/10.0	18.5/16.7/14.6	
	Motor (W)		60	60	60	60	
Sound pressure level		H/M/L (dB/A)	36/33/30	38/36/33	36/33/30	38/36/33	
Sound power level		H/M/L (dB/A)	51/48/45	53/51/48	51/48/45	53/51/48	
Outdoor unit							
Outer dimension	Max. total length (m)		70	70	70	70	
	Min. length (m)		7.5	7.5	7.5	7.5	
	Height difference	Outdoor lower (m)	30	30	30	30	
		Outdoor high (m)	30	30	30	30	
Fan unit	Fan		Propeller fan	Propeller fan	Propeller fan	Propeller fan	
	Standard air flow high	(m3/min)	133	133	133	133	
	Motor (W)		100 + 100	100 + 100	100 + 100	100 + 100	
Connecting pipe	Outdoor unit - First pipe branch		Gas side (mm)	28.6	28.6	28.6	28.6
			Liquid side (mm)	12.7	12.7	12.7	12.7
	First pipe branch - Second pipe branch		Gas side (mm)	15.9	15.9	15.9	15.9
			Liquid side (mm)	9.5	9.5	9.5	9.5
	Second pipe branch - Indoor unit		Gas side (mm)	12.7	15.9	12.7	15.9
			Liquid side (mm)	6.4	9.5	6.4	9.5
Sound pressure level		Cooling/Heating (dB/A)	56/57	57/58	56/57	57/58	
Sound power level		Cooling/Heating (dB/A)	72/74	74/75	72/74	74/75	

* IEC standard

1-1-13. Indoor unit (High wall Type)

<Double twin type>

Model		Indoor unit 1		RAV-SM562KRT-E	RAV-SM802KRT-E	RAV-SM562KRT-E	RAV-SM802KRT-E
		Indoor unit 2		RAV-SM562KRT-E	RAV-SM802KRT-E	RAV-SM562KRT-E	RAV-SM802KRT-E
		Indoor unit 3		RAV-SM562KRT-E	RAV-SM802KRT-E	RAV-SM562KRT-E	RAV-SM802KRT-E
		Indoor unit 4		RAV-SM562KRT-E	RAV-SM802KRT-E	RAV-SM562KRT-E	RAV-SM802KRT-E
		Outdoor unit		RAV-SM2244AT8-E	RAV-SM2804AT8-E	RAV-SM2244AT7	RAV-SM2804AT7
Cooling capacity (min. - max.)		(kW)	20.0 (9.8-22.4)	23.0 (9.8-27.0)	20.0 (9.8-22.4)	23.0 (9.8-27.0)	
Heating capacity (min. - max.)		(kW)	22.4 (9.8-25.0)	27.0 (9.8-31.5)	22.4 (9.8-25.0)	27.0 (9.8-31.5)	
Power supply			3 phase 380-415V 50Hz		3 phase 380V 60Hz		
Indoor unit							
Electrical characteristics	Cooling	Running current (A)		11.51 - 10.54	15.44 - 14.13	11.51	15.44
		Power consumption (min. - max.) (kW)		7.12 (2.37-9.28)	9.55 (2.37-13.39)	7.12 (2.37-9.28)	9.55 (2.37-13.39)
		Power factor (%)		94	94	94	94
		EER		2.81	2.41	2.81	2.41
		Energy efficiency class *		C	E	C	E
	Heating	Running current (A)		10.34 - 9.47	12.80 - 11.72	10.34	12.80
		Power consumption (min. - max.) (kW)		6.40 (1.98-7.46)	7.92 (1.98-10.95)	6.40 (1.98-7.46)	7.92 (1.98-10.95)
		Power factor (%)		94	94	94	94
		COP		3.50	3.41	3.50	3.41
		Energy efficiency class *		B	B	B	B
Maximum current (A)		18	22	18	22		
Fan unit	Fan		Cross flow fan	Cross flow fan	Cross flow fan	Cross flow fan	
	Standard air flow	H/M/L (m3/min)	14.0/12.5/10.7	18.5/14.6/12.2	14.0/12.5/10.7	18.5/14.6/12.2	
	Motor (W)		30	30	30	30	
Sound pressure level		H/M/L (dB/A)	39/36/33	45/41/36	39/36/33	45/41/36	
Sound power level		H/M/L (dB/A)	54/51/48	60/56/51	54/51/48	60/56/51	
Outdoor unit							
Outer dimension	Max. total length (m)		70	70	70	70	
	Min. length (m)		7.5	7.5	7.5	7.5	
	Height difference	Outdoor lower (m)	30	30	30	30	
		Outdoor high (m)	30	30	30	30	
Fan unit	Fan		Propeller fan	Propeller fan	Propeller fan	Propeller fan	
	Standard air flow high (m3/min)		133	133	133	133	
	Motor (W)		100 + 100	100 + 100	100 + 100	100 + 100	
Connecting pipe	Outdoor unit - First pipe branch		Gas side (mm)	28.6	28.6	28.6	28.6
			Liquid side (mm)	12.7	12.7	12.7	12.7
	First pipe branch - Second pipe branch		Gas side (mm)	15.9	15.9	15.9	15.9
			Liquid side (mm)	9.5	9.5	9.5	9.5
	Second pipe branch - Indoor unit		Gas side (mm)	12.7	15.9	12.7	15.9
			Liquid side (mm)	6.4	9.5	6.4	9.5
Sound pressure level		Cooling/Heating (dB/A)	56/57	57/58	56/57	57/58	
Sound power level		Cooling/Heating (dB/A)	72/74	74/75	72/74	74/75	

* IEC standard

1-2. Outdoor Unit

Model	Outdoor unit		RAV-SM2244AT8-E	RAV-SM2804AT8-E	RAV-SM2244AT7	RAV-SM2804AT7	
Power supply			3 phase 380-415V 50Hz (Power exclusive to outdoor is required.)		3 phase 380V 60Hz (Power exclusive to outdoor is required.)		
Compressor	Type		Hermetic compressor		Hermetic compressor		
	Motor	(kW)	3.75	3.75	3.75	3.75	
	Pole		4	4	4	4	
Refrigerant charged			(kg)	5.9	5.9	5.9	
Refrigerant control			Pulse motor valve		Pulse motor valve		
Pipe	Max. total length		(m)	70	70	70	
	Min. length		(m)	7.5	7.5	7.5	
	Height difference	Outdoor lower	(m)	30	30	30	
		Outdoor higher	(m)	30	30	30	
Outer dimension	Height		(mm)	1540	1540	1540	
	Width		(mm)	900	900	900	
	Depth		(mm)	320	320	320	
Appearance			Silky shade (Muncel 1Y8.5-0.5)		Silky shade (Muncel 1Y8.5-0.5)		
Total weight			(kg)	134	134	134	
Heat exchanger			Finned tube		Finned tube		
Fan unit	Fan			Propeller fan		Propeller fan	
	Standard air flow		(m ³ /min)	133	133	133	133
	Motor		(W)	100 + 100	100 + 100	100 + 100	100 + 100
Connecting pipe (Outdoor unit side)	Gas side		(mm)	19.1	19.1	19.1	
	Liquid side		(mm)	12.7	12.7	12.7	
Sound pressure level		Cooling/ Heating	(dB/A)	56/57	57/58	56/57	
Sound power level		Cooling/ Heating	(dB/A)	72/74	74/75	72/74	
Outside air temperature, Cooling			(C)	46 to -15C		46 to -15C	
Outside air temperature, Heating			(C)	15 to -20C		15 to -20C	

* IEC standard

2 Construction views (External views)

2-1. Outdoor unit

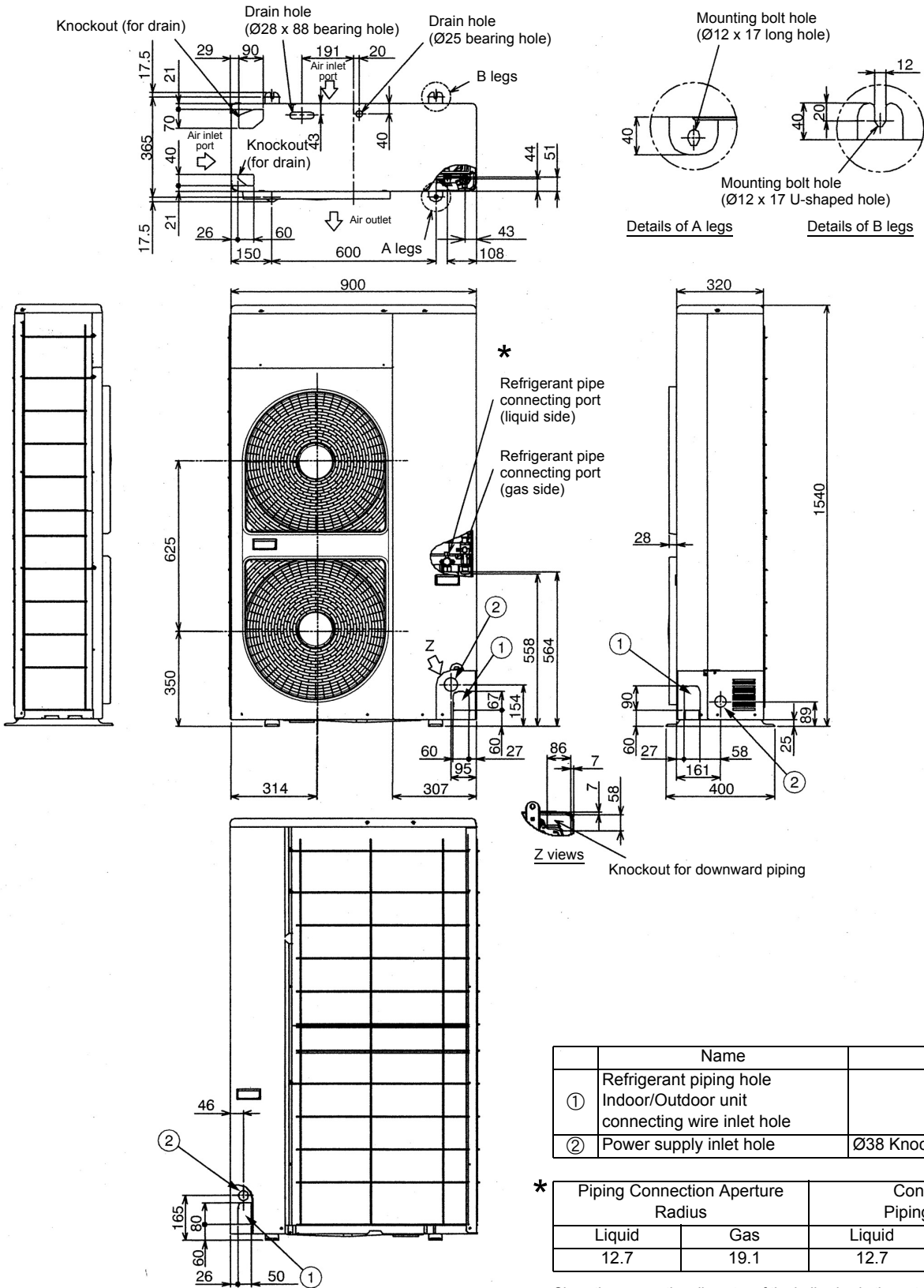

	Name	Note
①	Refrigerant piping hole Indoor/Outdoor unit connecting wire inlet hole	—
②	Power supply inlet hole	Ø38 Knockout hole

*

Piping Connection Aperture Radius		Connection Piping Radius	
Liquid	Gas	Liquid	Gas
12.7	19.1	12.7	28.6

Since the connection diameter of the ball valve in the outdoor unit main body is Ø19.1, use the attached coupling pipe when performing maintenance.

3 Gravity position

Digital Inverter Outdoor unit

Model Name	X(mm)	Y(mm)	Z(mm)	Weight (kg)
RAV-SM2244AT7	325	160	705	134
RAV-SM2244AT7Z				
RAV-SM2244AT7ZG				
RAV-SM2244AT8-E				
RAV-SM2244AT8Z-E				
RAV-SM2244AT8ZG-E				
RAV-SM2804AT7				
RAV-SM2804AT7Z				
RAV-SM2804AT7ZG				
RAV-SM2804AT8-E				
RAV-SM2804AT8Z-E				
RAV-SM2804AT8ZG-E				

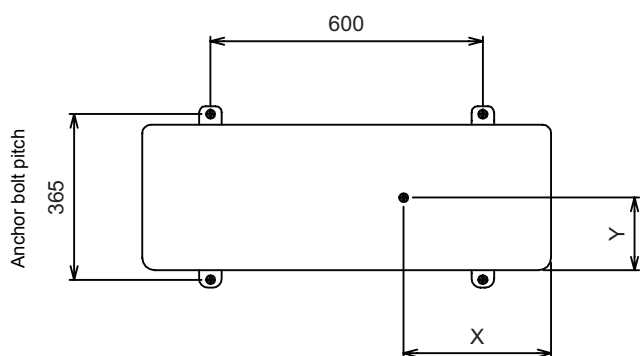

(Unit:mm)

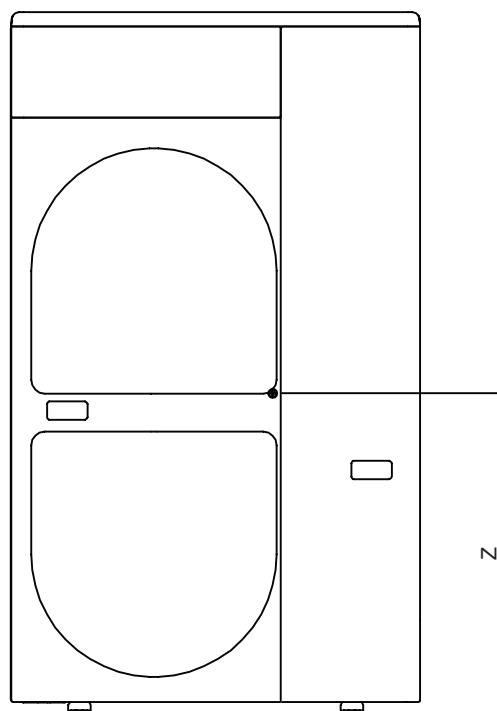

4 Wiring diagram

Model : RAV-SM2244AT8(Z)(ZG)-E, RAV-SM2804AT8(Z)(ZG)-E,
RAV-SM2244AT7(Z)(ZG), RAV-SM2804AT7(Z)(ZG)

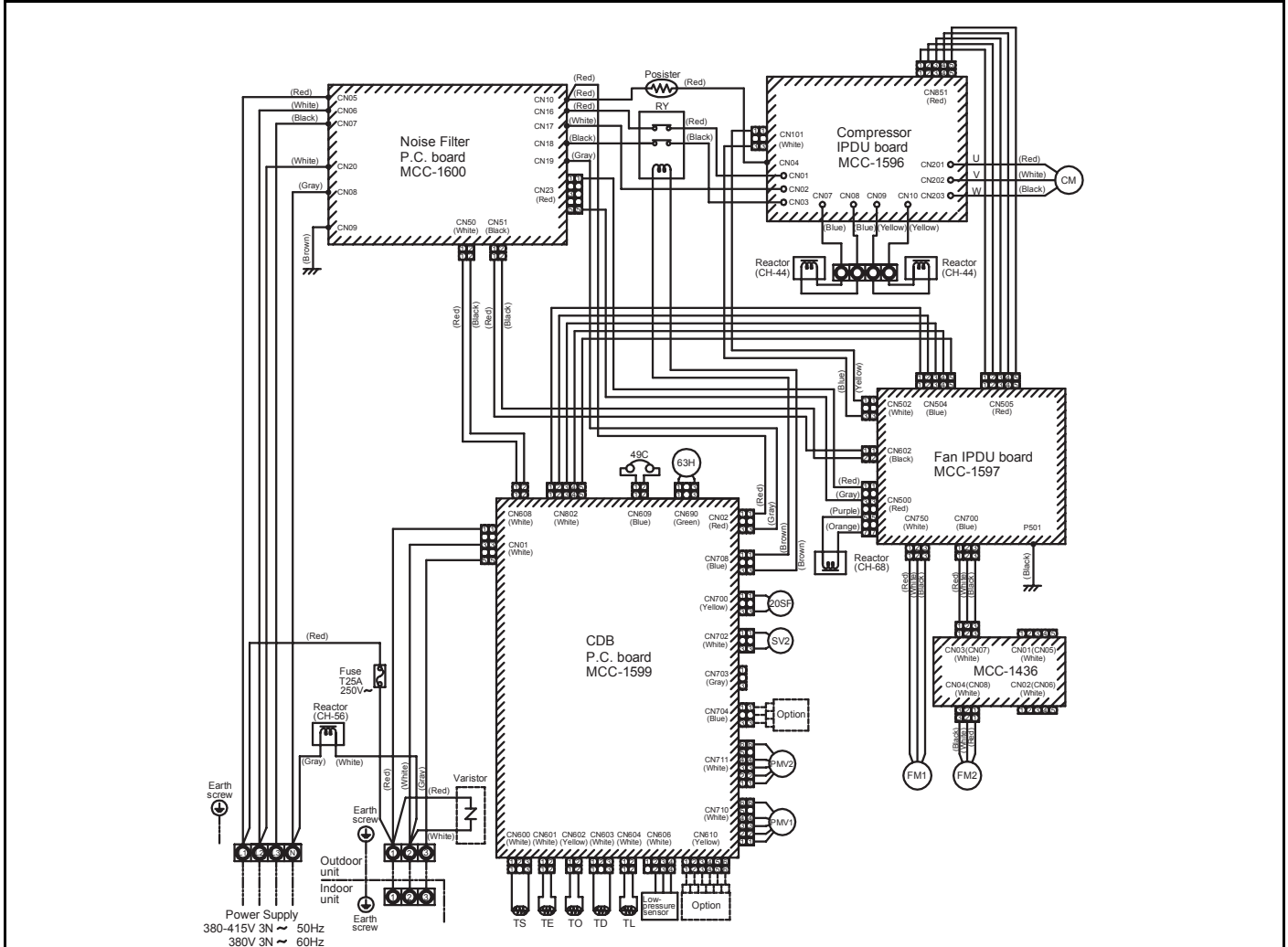

Model Name	Voltage frequency
RAV-SM****AT7,(Z),(ZG)	380V 3N ~ 60Hz
RAV-SM****AT8,(Z),(ZG)-E	380-415V 3N ~ 50Hz

Symbol	Part Name	Symbol	Part Name
CM	Compressor	TO	Outside temperature sensor
FM1, 2	Fan motor	SV2	2-way valve coil
PMV1, 2	Pulse motor valve	20SF	4-way valve coil
TD	Pipe temperature sensor(Discharge)	49C	Compressor case thermostat
TS	Pipe temperature sensor(Suction)	63H	High-pressure switch
TE	Heat exchanger sensor 1	RY	Relay
TL	Heat exchanger sensor 2		

1. © indicates the terminal block. Alphanumeric characters in the cycle indicate the terminal No.
2. The two-dot chain line indicates the wiring procured locally.
3. ▨ indicates the P.C. board.
4. For the indoor unit circuit, refer to the wiring diagram of the indoor unit.

5 Outdoor Unit refrigerating cycle diagram

RAV-SM2244AT8(Z)(ZG)-E, SM2804AT8(Z)(ZG)-E
RAV-SM2244AT7(Z)(ZG), SM2804AT7(Z)(ZG)

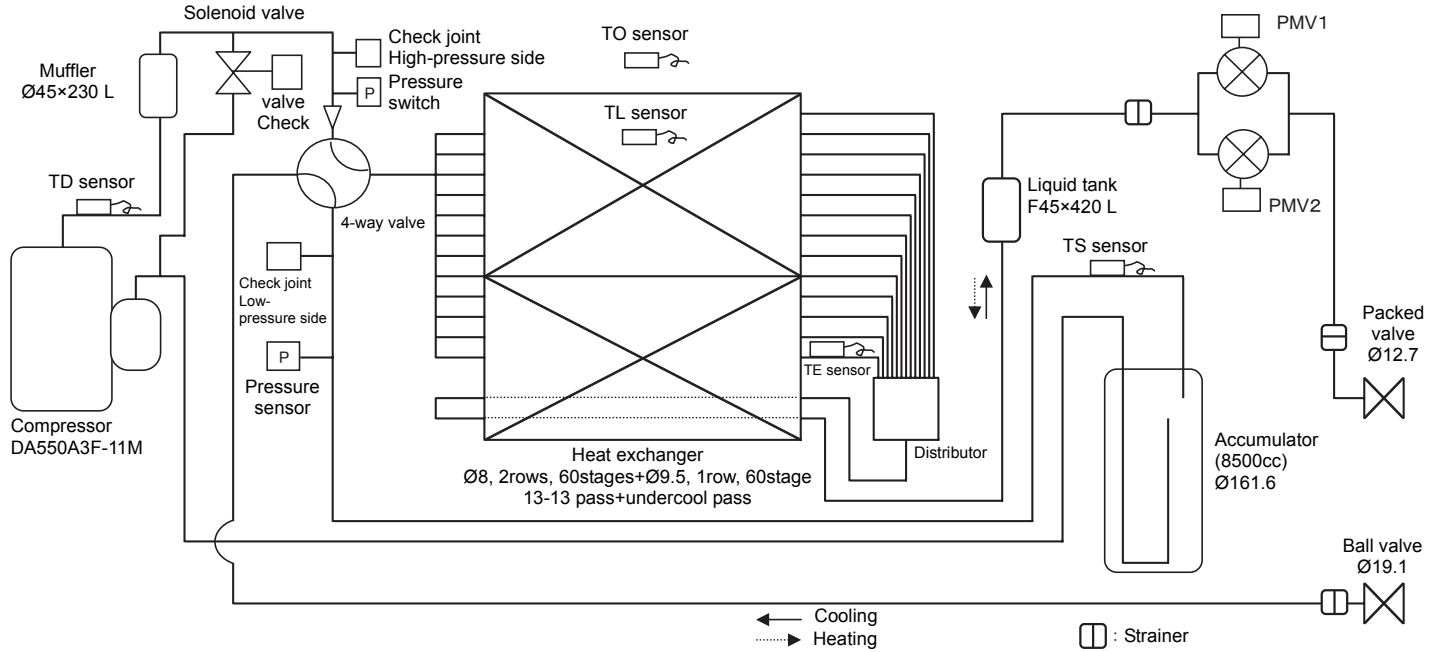

RAV-SM2244 series

		Pressure				Pipe surface temperature (°C)				Compressor drive revolution frequency (rps)*	Indoor fan	Indoor/Outdoor temp. conditions (DB/WB) (°C)	
		(MPa)		(kg/cm ² g)		Discharge (TD)	Suction (TS)	Indoor heat exchanger (TC)	Outdoor heat exchanger (TE)			Indoor	Outdoor
		Pd	Ps	Pd	Ps								
Cooling	Standard	3.14	0.88	32.0	9.0	84	14	10	37	64	HIGH	27/19	35/-
	Overload	3.54	1.14	36.1	11.6	88	17	16	46	62	HIGH	32/24	43/-
	Low load	1.65	0.65	16.8	6.6	41	7	5	0	36	LOW	18/15.5	-15/-
Heating	Standard	2.60	0.67	26.5	6.8	73	2	42	2	66	HIGH	20/-	7/6
	Overload	3.24	1.08	33.1	11.0	77	14	52	13	36	LOW	30/-	24/18
	Low load	2.05	0.31	20.9	3.2	76	-12	34	-11	75	HIGH	15/-	-10/ (70%)

RAV-SM2804 series

		Pressure				Pipe surface temperature (°C)				Compressor drive revolution frequency (rps)*	Indoor fan	Indoor/Outdoor temp. conditions (DB/WB) (°C)	
		(MPa)		(kg/cm ² g)		Discharge (TD)	Suction (TS)	Indoor heat exchanger (TC)	Outdoor heat exchanger (TE)			Indoor	Outdoor
		Pd	Ps	Pd	Ps								
Cooling	Standard	3.15	0.79	32.1	8.1	87	11	9	41	80	HIGH	27/19	35/-
	Overload	3.62	1.12	36.9	11.4	89	18	16	48	64	HIGH	32/24	43/-
	Low load	1.66	0.64	16.9	6.5	42	6	5	0	36	LOW	18/15.5	-15/-
Heating	Standard	2.85	0.63	29.1	6.4	80	1	47	2	78	HIGH	20/-	7/6
	Overload	3.26	1.06	33.3	10.8	78	14	53	12	36	LOW	30/-	24/18
	Low load	2.05	0.29	20.9	3	81	-13	33	-12	96	HIGH	15/-	-15/-

* This compressor has 4-pole motor.

The value when compressor frequency (Hz) is measured by a clamp meter becomes 2 times of No. of compressor revolutions (rps).

6 Sensible capacity table

Digital Inverter 8,10HP Sensible Heat Capacity: RAV-SM***UT-E

		indoor air temp.																	
Outdoor unit size	outdoor air temp. CDB	14.0CWB 20.0CDB		15.0CWB 21.5CDB		16.0CWB 23.0CDB		17.0CWB 24.5CDB		18.0CWB 26.0CDB		19.0CWB 27.0CDB		20.0CWB 28.0CDB		22.0CWB 30.0CDB		24.0CWB 32.0CDB	
		TC	SHC	TC	SHC	TC	SHC	TC	SHC	TC	SHC	TC	SHC	TC	SHC	TC	SHC	TC	SHC
2244	10.0	20.8	16.6	21.9	17.4	23.0	18.3	23.8	18.9	24.6	19.6	25.4	20.2	26.1	20.7	27.6	22.0	28.9	23.0
	12.0	20.5	16.3	21.5	17.1	22.6	18.0	23.4	18.6	24.2	19.2	24.9	19.8	25.6	20.4	27.1	21.6	28.4	22.6
	14.0	20.1	16.0	21.2	16.8	22.2	17.7	23.0	18.3	23.8	18.9	24.5	19.5	25.2	20.0	26.7	21.2	27.9	22.2
	16.0	19.8	15.7	20.8	16.5	21.8	17.4	22.6	18.0	23.4	18.6	24.1	19.1	24.8	19.7	26.2	20.8	27.4	21.8
	18.0	19.4	15.4	20.4	16.2	21.4	17.0	22.2	17.7	23.0	18.3	23.6	18.8	24.3	19.3	25.7	20.5	26.9	21.4
	20.0	19.1	15.2	20.1	15.9	21.1	16.7	21.8	17.3	22.5	17.9	23.2	18.5	23.9	19.0	25.3	20.1	26.4	21.0
	21.0	18.9	15.0	19.9	15.8	20.9	16.6	21.6	17.2	22.3	17.8	23.0	18.3	23.7	18.8	25.0	19.9	26.2	20.8
	23.0	18.5	14.7	19.5	15.5	20.5	16.3	21.2	16.9	21.9	17.4	22.6	17.9	23.2	18.5	24.6	19.5	25.7	20.4
	25.0	18.2	14.5	19.1	15.2	20.1	16.0	20.8	16.5	21.5	17.1	22.1	17.6	22.8	18.1	24.1	19.2	25.2	20.1
	27.0	17.8	14.2	18.8	14.9	19.7	15.7	20.4	16.2	21.1	16.8	21.7	17.3	22.3	17.8	23.7	18.8	24.7	19.7
	29.0	17.5	13.9	18.4	14.6	19.3	15.3	20.0	15.9	20.7	16.4	21.3	16.9	21.9	17.4	23.2	18.4	24.2	19.3
	31.0	17.1	13.6	18.0	14.3	18.9	15.0	19.6	15.6	20.3	16.1	20.9	16.6	21.5	17.1	22.7	18.1	23.8	18.9
	33.0	16.8	13.3	17.7	14.0	18.5	14.7	19.2	15.3	19.8	15.8	20.4	16.2	21.0	16.7	22.3	17.7	23.3	18.5
	35.0	16.4	13.1	17.3	13.7	18.1	14.4	18.8	14.9	19.4	15.4	20.0	15.9	20.6	16.4	21.8	17.3	22.8	18.1
37.0	16.1	12.8	16.9	13.4	17.8	14.1	18.4	14.6	19.0	15.1	19.6	15.6	20.1	16.0	21.3	16.9	22.3	17.7	
39.0	15.7	12.5	16.5	13.2	17.4	13.8	18.0	14.3	18.6	14.8	19.1	15.2	19.7	15.7	20.9	16.6	21.8	17.3	

		indoor air temp.																	
Outdoor unit size	outdoor air temp. CDB	14.0CWB 20.0CDB		15.0CWB 21.5CDB		16.0CWB 23.0CDB		17.0CWB 24.5CDB		18.0CWB 26.0CDB		19.0CWB 27.0CDB		20.0CWB 28.0CDB		22.0CWB 30.0CDB		24.0CWB 32.0CDB	
		TC	SHC	TC	SHC	TC	SHC	TC	SHC	TC	SHC	TC	SHC	TC	SHC	TC	SHC	TC	SHC
2804	10.0	23.9	18.3	25.2	19.3	26.4	20.2	27.4	21.0	28.3	21.7	29.2	22.3	30.0	22.9	31.8	24.3	33.2	25.4
	12.0	23.5	18.0	24.8	19.0	26.0	19.9	26.9	20.6	27.8	21.3	28.7	21.9	29.5	22.6	31.2	23.9	32.7	25.0
	14.0	23.1	17.7	24.3	18.6	25.6	19.6	26.5	20.2	27.4	20.9	28.2	21.6	29.0	22.2	30.7	23.5	32.1	24.6
	16.0	22.7	17.4	23.9	18.3	25.1	19.2	26.0	19.9	26.9	20.6	27.7	21.2	28.5	21.8	30.1	23.1	31.5	24.1
	18.0	22.3	17.1	23.5	18.0	24.7	18.9	25.5	19.5	26.4	20.2	27.2	20.8	28.0	21.4	29.6	22.7	31.0	23.7
	20.0	21.9	16.8	23.1	17.7	24.2	18.5	25.1	19.2	25.9	19.8	26.7	20.4	27.5	21.0	29.1	22.2	30.4	23.3
	21.0	21.7	16.6	22.9	17.5	24.0	18.4	24.8	19.0	25.7	19.7	26.4	20.2	27.2	20.8	28.8	22.0	30.1	23.1
	23.0	21.3	16.3	22.4	17.2	23.5	18.0	24.4	18.7	25.2	19.3	26.0	19.9	26.7	20.4	28.3	21.6	29.6	22.6
	25.0	20.9	16.0	22.0	16.8	23.1	17.7	23.9	18.3	24.7	18.9	25.5	19.5	26.2	20.0	27.7	21.2	29.0	22.2
	27.0	20.5	15.7	21.6	16.5	22.6	17.3	23.5	17.9	24.3	18.6	25.0	19.1	25.7	19.7	27.2	20.8	28.4	21.8
	29.0	20.1	15.4	21.2	16.2	22.2	17.0	23.0	17.6	23.8	18.2	24.5	18.7	25.2	19.3	26.7	20.4	27.9	21.3
	31.0	19.7	15.1	20.7	15.9	21.8	16.6	22.5	17.2	23.3	17.8	24.0	18.4	24.7	18.9	26.1	20.0	27.3	20.9
	33.0	19.3	14.8	20.3	15.5	21.3	16.3	22.1	16.9	22.8	17.5	23.5	18.0	24.2	18.5	25.6	19.6	26.8	20.5
	35.0	18.9	14.5	19.9	15.2	20.9	16.0	21.6	16.5	22.3	17.1	23.0	17.6	23.7	18.1	25.1	19.2	26.2	20.1
37.0	18.5	14.1	19.5	14.9	20.4	15.6	21.1	16.2	21.9	16.7	22.5	17.2	23.2	17.7	24.5	18.8	25.6	19.6	
39.0	18.1	13.8	19.0	14.6	20.0	15.3	20.7	15.8	21.4	16.4	22.0	16.8	22.6	17.3	24.0	18.4	25.1	19.2	

TC:Total Capacity [kW]
SHC:Sensible Heat Capacity [kW]

Digital Inverter 8,10HP Sensible Heat Capacity: RAV-SM***BT-E

		indoor air temp.																	
Outdoor unit size	outdoor air temp. CDB	14.0CWB 20.0CDB		15.0CWB 21.5CDB		16.0CWB 23.0CDB		17.0CWB 24.5CDB		18.0CWB 26.0CDB		19.0CWB 27.0CDB		20.0CWB 28.0CDB		22.0CWB 30.0CDB		24.0CWB 32.0CDB	
		TC	SHC	TC	SHC	TC	SHC	TC	SHC	TC	SHC	TC	SHC	TC	SHC	TC	SHC	TC	SHC
2244	10.0	20.8	14.6	21.9	15.3	23.0	16.1	23.8	16.7	24.6	17.2	25.4	17.7	26.1	18.3	27.6	19.3	28.9	20.2
	12.0	20.5	14.3	21.5	15.1	22.6	15.8	23.4	16.4	24.2	16.9	24.9	17.4	25.6	17.9	27.1	19.0	28.4	19.9
	14.0	20.1	14.1	21.2	14.8	22.2	15.6	23.0	16.1	23.8	16.7	24.5	17.1	25.2	17.6	26.7	18.7	27.9	19.5
	16.0	19.8	13.8	20.8	14.6	21.8	15.3	22.6	15.8	23.4	16.4	24.1	16.8	24.8	17.3	26.2	18.4	27.4	19.2
	18.0	19.4	13.6	20.4	14.3	21.4	15.0	22.2	15.5	23.0	16.1	23.6	16.5	24.3	17.0	25.7	18.0	26.9	18.9
	20.0	19.1	13.3	20.1	14.0	21.1	14.7	21.8	15.3	22.5	15.8	23.2	16.2	23.9	16.7	25.3	17.7	26.4	18.5
	21.0	18.9	13.2	19.9	13.9	20.9	14.6	21.6	15.1	22.3	15.6	23.0	16.1	23.7	16.6	25.0	17.5	26.2	18.3
	23.0	18.5	13.0	19.5	13.7	20.5	14.3	21.2	14.8	21.9	15.3	22.6	15.8	23.2	16.2	24.6	17.2	25.7	18.0
	25.0	18.2	12.7	19.1	13.4	20.1	14.1	20.8	14.6	21.5	15.1	22.1	15.5	22.8	15.9	24.1	16.9	25.2	17.7
	27.0	17.8	12.5	18.8	13.1	19.7	13.8	20.4	14.3	21.1	14.8	21.7	15.2	22.3	15.6	23.7	16.6	24.7	17.3
	29.0	17.5	12.2	18.4	12.9	19.3	13.5	20.0	14.0	20.7	14.5	21.3	14.9	21.9	15.3	23.2	16.2	24.2	17.0
	31.0	17.1	12.0	18.0	12.6	18.9	13.2	19.6	13.7	20.3	14.2	20.9	14.6	21.5	15.0	22.7	15.9	23.8	16.6
	33.0	16.8	11.7	17.7	12.4	18.5	13.0	19.2	13.4	19.8	13.9	20.4	14.3	21.0	14.7	22.3	15.6	23.3	16.3
	35.0	16.4	11.5	17.3	12.1	18.1	12.7	18.8	13.1	19.4	13.6	20.0	14.0	20.6	14.4	21.8	15.3	22.8	16.0
	37.0	16.1	11.3	16.9	11.8	17.8	12.4	18.4	12.9	19.0	13.3	19.6	13.7	20.1	14.1	21.3	14.9	22.3	15.6
39.0	15.7	11.0	16.5	11.6	17.4	12.2	18.0	12.6	18.6	13.0	19.1	13.4	19.7	13.8	20.9	14.6	21.8	15.3	

		indoor air temp.																	
Outdoor unit size	outdoor air temp. CDB	14.0CWB 20.0CDB		15.0CWB 21.5CDB		16.0CWB 23.0CDB		17.0CWB 24.5CDB		18.0CWB 26.0CDB		19.0CWB 27.0CDB		20.0CWB 28.0CDB		22.0CWB 30.0CDB		24.0CWB 32.0CDB	
		TC	SHC	TC	SHC	TC	SHC	TC	SHC	TC	SHC	TC	SHC	TC	SHC	TC	SHC	TC	SHC
2804	10.0	23.9	16.1	25.2	17.0	26.4	17.8	27.4	18.5	28.3	19.1	29.2	19.6	30.0	20.2	31.8	21.4	33.2	22.4
	12.0	23.5	15.9	24.8	16.7	26.0	17.5	26.9	18.1	27.8	18.8	28.7	19.3	29.5	19.9	31.2	21.0	32.7	22.0
	14.0	23.1	15.6	24.3	16.4	25.6	17.2	26.5	17.8	27.4	18.4	28.2	19.0	29.0	19.5	30.7	20.7	32.1	21.6
	16.0	22.7	15.3	23.9	16.1	25.1	16.9	26.0	17.5	26.9	18.1	27.7	18.7	28.5	19.2	30.1	20.3	31.5	21.2
	18.0	22.3	15.0	23.5	15.8	24.7	16.6	25.5	17.2	26.4	17.8	27.2	18.3	28.0	18.8	29.6	20.0	31.0	20.9
	20.0	21.9	14.8	23.1	15.5	24.2	16.3	25.1	16.9	25.9	17.5	26.7	18.0	27.5	18.5	29.1	19.6	30.4	20.5
	21.0	21.7	14.6	22.9	15.4	24.0	16.2	24.8	16.7	25.7	17.3	26.4	17.8	27.2	18.3	28.8	19.4	30.1	20.3
	23.0	21.3	14.4	22.4	15.1	23.5	15.9	24.4	16.4	25.2	17.0	26.0	17.5	26.7	18.0	28.3	19.1	29.6	19.9
	25.0	20.9	14.1	22.0	14.8	23.1	15.6	23.9	16.1	24.7	16.7	25.5	17.2	26.2	17.6	27.7	18.7	29.0	19.5
	27.0	20.5	13.8	21.6	14.5	22.6	15.3	23.5	15.8	24.3	16.3	25.0	16.8	25.7	17.3	27.2	18.3	28.4	19.2
	29.0	20.1	13.5	21.2	14.3	22.2	15.0	23.0	15.5	23.8	16.0	24.5	16.5	25.2	17.0	26.7	18.0	27.9	18.8
	31.0	19.7	13.3	20.7	14.0	21.8	14.7	22.5	15.2	23.3	15.7	24.0	16.2	24.7	16.6	26.1	17.6	27.3	18.4
	33.0	19.3	13.0	20.3	13.7	21.3	14.4	22.1	14.9	22.8	15.4	23.5	15.8	24.2	16.3	25.6	17.2	26.8	18.0
	35.0	18.9	12.7	19.9	13.4	20.9	14.1	21.6	14.6	22.3	15.1	23.0	15.5	23.7	15.9	25.1	16.9	26.2	17.7
	37.0	18.5	12.5	19.5	13.1	20.4	13.8	21.1	14.2	21.9	14.7	22.5	15.2	23.2	15.6	24.5	16.5	25.6	17.3
39.0	18.1	12.2	19.0	12.8	20.0	13.5	20.7	13.9	21.4	14.4	22.0	14.8	22.6	15.3	24.0	16.2	25.1	16.9	

TC:Total Capacity [kW]

SHC:Sensible Heat Capacity [kW]

Digital Inverter 8,10HP Sensible Heat Capacity: RAV-SM***CT-E

		indoor air temp.																	
Outdoor unit size	outdoor air temp. CDB	14.0CWB 20.0CDB		15.0CWB 21.5CDB		16.0CWB 23.0CDB		17.0CWB 24.5CDB		18.0CWB 26.0CDB		19.0CWB 27.0CDB		20.0CWB 28.0CDB		22.0CWB 30.0CDB		24.0CWB 32.0CDB	
		TC	SHC	TC	SHC	TC	SHC	TC	SHC	TC	SHC	TC	SHC	TC	SHC	TC	SHC	TC	SHC
2244	10.0	20.8	14.6	21.9	15.3	23.0	16.1	23.8	16.7	24.6	17.2	25.4	17.7	26.1	18.3	27.6	19.3	28.9	20.2
	12.0	20.5	14.3	21.5	15.1	22.6	15.8	23.4	16.4	24.2	16.9	24.9	17.4	25.6	17.9	27.1	19.0	28.4	19.9
	14.0	20.1	14.1	21.2	14.8	22.2	15.6	23.0	16.1	23.8	16.7	24.5	17.1	25.2	17.6	26.7	18.7	27.9	19.5
	16.0	19.8	13.8	20.8	14.6	21.8	15.3	22.6	15.8	23.4	16.4	24.1	16.8	24.8	17.3	26.2	18.4	27.4	19.2
	18.0	19.4	13.6	20.4	14.3	21.4	15.0	22.2	15.5	23.0	16.1	23.6	16.5	24.3	17.0	25.7	18.0	26.9	18.9
	20.0	19.1	13.3	20.1	14.0	21.1	14.7	21.8	15.3	22.5	15.8	23.2	16.2	23.9	16.7	25.3	17.7	26.4	18.5
	21.0	18.9	13.2	19.9	13.9	20.9	14.6	21.6	15.1	22.3	15.6	23.0	16.1	23.7	16.6	25.0	17.5	26.2	18.3
	23.0	18.5	13.0	19.5	13.7	20.5	14.3	21.2	14.8	21.9	15.3	22.6	15.8	23.2	16.2	24.6	17.2	25.7	18.0
	25.0	18.2	12.7	19.1	13.4	20.1	14.1	20.8	14.6	21.5	15.1	22.1	15.5	22.8	15.9	24.1	16.9	25.2	17.7
	27.0	17.8	12.5	18.8	13.1	19.7	13.8	20.4	14.3	21.1	14.8	21.7	15.2	22.3	15.6	23.7	16.6	24.7	17.3
	29.0	17.5	12.2	18.4	12.9	19.3	13.5	20.0	14.0	20.7	14.5	21.3	14.9	21.9	15.3	23.2	16.2	24.2	17.0
	31.0	17.1	12.0	18.0	12.6	18.9	13.2	19.6	13.7	20.3	14.2	20.9	14.6	21.5	15.0	22.7	15.9	23.8	16.6
	33.0	16.8	11.7	17.7	12.4	18.5	13.0	19.2	13.4	19.8	13.9	20.4	14.3	21.0	14.7	22.3	15.6	23.3	16.3
	35.0	16.4	11.5	17.3	12.1	18.1	12.7	18.8	13.1	19.4	13.6	20.0	14.0	20.6	14.4	21.8	15.3	22.8	16.0
	37.0	16.1	11.3	16.9	11.8	17.8	12.4	18.4	12.9	19.0	13.3	19.6	13.7	20.1	14.1	21.3	14.9	22.3	15.6
39.0	15.7	11.0	16.5	11.6	17.4	12.2	18.0	12.6	18.6	13.0	19.1	13.4	19.7	13.8	20.9	14.6	21.8	15.3	

		indoor air temp.																	
Outdoor unit size	outdoor air temp. CDB	14.0CWB 20.0CDB		15.0CWB 21.5CDB		16.0CWB 23.0CDB		17.0CWB 24.5CDB		18.0CWB 26.0CDB		19.0CWB 27.0CDB		20.0CWB 28.0CDB		22.0CWB 30.0CDB		24.0CWB 32.0CDB	
		TC	SHC	TC	SHC	TC	SHC	TC	SHC	TC	SHC	TC	SHC	TC	SHC	TC	SHC	TC	SHC
2804	10.0	23.9	16.0	25.2	16.9	26.4	17.7	27.4	18.3	28.3	19.0	29.2	19.5	30.0	20.1	31.8	21.3	33.2	22.2
	12.0	23.5	15.8	24.8	16.6	26.0	17.4	26.9	18.0	27.8	18.6	28.7	19.2	29.5	19.7	31.2	20.9	32.7	21.9
	14.0	23.1	15.5	24.3	16.3	25.6	17.1	26.5	17.7	27.4	18.3	28.2	18.9	29.0	19.4	30.7	20.5	32.1	21.5
	16.0	22.7	15.2	23.9	16.0	25.1	16.8	26.0	17.4	26.9	18.0	27.7	18.5	28.5	19.1	30.1	20.2	31.5	21.1
	18.0	22.3	15.0	23.5	15.7	24.7	16.5	25.5	17.1	26.4	17.7	27.2	18.2	28.0	18.7	29.6	19.8	31.0	20.7
	20.0	21.9	14.7	23.1	15.4	24.2	16.2	25.1	16.8	25.9	17.4	26.7	17.9	27.5	18.4	29.1	19.5	30.4	20.4
	21.0	21.7	14.5	22.9	15.3	24.0	16.1	24.8	16.6	25.7	17.2	26.4	17.7	27.2	18.2	28.8	19.3	30.1	20.2
	23.0	21.3	14.3	22.4	15.0	23.5	15.8	24.4	16.3	25.2	16.9	26.0	17.4	26.7	17.9	28.3	18.9	29.6	19.8
	25.0	20.9	14.0	22.0	14.7	23.1	15.5	23.9	16.0	24.7	16.6	25.5	17.0	26.2	17.5	27.7	18.6	29.0	19.4
	27.0	20.5	13.7	21.6	14.4	22.6	15.2	23.5	15.7	24.3	16.2	25.0	16.7	25.7	17.2	27.2	18.2	28.4	19.0
	29.0	20.1	13.5	21.2	14.2	22.2	14.9	23.0	15.4	23.8	15.9	24.5	16.4	25.2	16.9	26.7	17.9	27.9	18.7
	31.0	19.7	13.2	20.7	13.9	21.8	14.6	22.5	15.1	23.3	15.6	24.0	16.1	24.7	16.5	26.1	17.5	27.3	18.3
	33.0	19.3	12.9	20.3	13.6	21.3	14.3	22.1	14.8	22.8	15.3	23.5	15.7	24.2	16.2	25.6	17.1	26.8	17.9
	35.0	18.9	12.6	19.9	13.3	20.9	14.0	21.6	14.5	22.3	15.0	23.0	15.4	23.7	15.8	25.1	16.8	26.2	17.5
	37.0	18.5	12.4	19.5	13.0	20.4	13.7	21.1	14.2	21.9	14.6	22.5	15.1	23.2	15.5	24.5	16.4	25.6	17.2
39.0	18.1	12.1	19.0	12.7	20.0	13.4	20.7	13.8	21.4	14.3	22.0	14.7	22.6	15.2	24.0	16.1	25.1	16.8	

TC:Total Capacity [kW]

SHC:Sensible Heat Capacity [kW]

Digital Inverter 8,10HP Sensible Heat Capacity: RAV-SM*KRT-E**

		indoor air temp.																	
Outdoor unit size	outdoor air temp. CDB	14.0CWB 20.0CDB		15.0CWB 21.5CDB		16.0CWB 23.0CDB		17.0CWB 24.5CDB		18.0CWB 26.0CDB		19.0CWB 27.0CDB		20.0CWB 28.0CDB		22.0CWB 30.0CDB		24.0CWB 32.0CDB	
		TC	SHC	TC	SHC	TC	SHC	TC	SHC	TC	SHC	TC	SHC	TC	SHC	TC	SHC	TC	SHC
2244	10.0	20.8	14.4	21.9	15.1	23.0	15.9	23.8	16.4	24.6	17.0	25.4	17.5	26.1	18.0	27.6	19.1	28.9	19.9
	12.0	20.5	14.1	21.5	14.9	22.6	15.6	23.4	16.2	24.2	16.7	24.9	17.2	25.6	17.7	27.1	18.7	28.4	19.6
	14.0	20.1	13.9	21.2	14.6	22.2	15.3	23.0	15.9	23.8	16.4	24.5	16.9	25.2	17.4	26.7	18.4	27.9	19.3
	16.0	19.8	13.6	20.8	14.4	21.8	15.1	22.6	15.6	23.4	16.1	24.1	16.6	24.8	17.1	26.2	18.1	27.4	18.9
	18.0	19.4	13.4	20.4	14.1	21.4	14.8	22.2	15.3	23.0	15.8	23.6	16.3	24.3	16.8	25.7	17.8	26.9	18.6
	20.0	19.1	13.2	20.1	13.8	21.1	14.5	21.8	15.0	22.5	15.6	23.2	16.0	23.9	16.5	25.3	17.4	26.4	18.2
	21.0	18.9	13.0	19.9	13.7	20.9	14.4	21.6	14.9	22.3	15.4	23.0	15.9	23.7	16.3	25.0	17.3	26.2	18.1
	23.0	18.5	12.8	19.5	13.5	20.5	14.1	21.2	14.6	21.9	15.1	22.6	15.6	23.2	16.0	24.6	17.0	25.7	17.7
	25.0	18.2	12.5	19.1	13.2	20.1	13.9	20.8	14.3	21.5	14.8	22.1	15.3	22.8	15.7	24.1	16.6	25.2	17.4
	27.0	17.8	12.3	18.8	12.9	19.7	13.6	20.4	14.1	21.1	14.6	21.7	15.0	22.3	15.4	23.7	16.3	24.7	17.1
	29.0	17.5	12.1	18.4	12.7	19.3	13.3	20.0	13.8	20.7	14.3	21.3	14.7	21.9	15.1	23.2	16.0	24.2	16.7
	31.0	17.1	11.8	18.0	12.4	18.9	13.1	19.6	13.5	20.3	14.0	20.9	14.4	21.5	14.8	22.7	15.7	23.8	16.4
	33.0	16.8	11.6	17.7	12.2	18.5	12.8	19.2	13.2	19.8	13.7	20.4	14.1	21.0	14.5	22.3	15.4	23.3	16.1
	35.0	16.4	11.3	17.3	11.9	18.1	12.5	18.8	13.0	19.4	13.4	20.0	13.8	20.6	14.2	21.8	15.0	22.8	15.7
	37.0	16.1	11.1	16.9	11.7	17.8	12.3	18.4	12.7	19.0	13.1	19.6	13.5	20.1	13.9	21.3	14.7	22.3	15.4
39.0	15.7	10.9	16.5	11.4	17.4	12.0	18.0	12.4	18.6	12.8	19.1	13.2	19.7	13.6	20.9	14.4	21.8	15.0	

		indoor air temp.																	
Outdoor unit size	outdoor air temp. CDB	14.0CWB 20.0CDB		15.0CWB 21.5CDB		16.0CWB 23.0CDB		17.0CWB 24.5CDB		18.0CWB 26.0CDB		19.0CWB 27.0CDB		20.0CWB 28.0CDB		22.0CWB 30.0CDB		24.0CWB 32.0CDB	
		TC	SHC	TC	SHC	TC	SHC	TC	SHC	TC	SHC	TC	SHC	TC	SHC	TC	SHC	TC	SHC
2804	10.0	23.9	15.8	25.2	16.7	26.4	17.5	27.4	18.1	28.3	18.7	29.2	19.3	30.0	19.8	31.8	21.0	33.2	21.9
	12.0	23.5	15.6	24.8	16.4	26.0	17.2	26.9	17.8	27.8	18.4	28.7	18.9	29.5	19.5	31.2	20.6	32.7	21.6
	14.0	23.1	15.3	24.3	16.1	25.6	16.9	26.5	17.5	27.4	18.1	28.2	18.6	29.0	19.1	30.7	20.3	32.1	21.2
	16.0	22.7	15.0	23.9	15.8	25.1	16.6	26.0	17.2	26.9	17.8	27.7	18.3	28.5	18.8	30.1	19.9	31.5	20.8
	18.0	22.3	14.8	23.5	15.5	24.7	16.3	25.5	16.9	26.4	17.5	27.2	18.0	28.0	18.5	29.6	19.6	31.0	20.5
	20.0	21.9	14.5	23.1	15.2	24.2	16.0	25.1	16.6	25.9	17.1	26.7	17.6	27.5	18.1	29.1	19.2	30.4	20.1
	21.0	21.7	14.4	22.9	15.1	24.0	15.9	24.8	16.4	25.7	17.0	26.4	17.5	27.2	18.0	28.8	19.0	30.1	19.9
	23.0	21.3	14.1	22.4	14.8	23.5	15.6	24.4	16.1	25.2	16.7	26.0	17.2	26.7	17.6	28.3	18.7	29.6	19.5
	25.0	20.9	13.8	22.0	14.5	23.1	15.3	23.9	15.8	24.7	16.3	25.5	16.8	26.2	17.3	27.7	18.3	29.0	19.2
	27.0	20.5	13.6	21.6	14.3	22.6	15.0	23.5	15.5	24.3	16.0	25.0	16.5	25.7	17.0	27.2	18.0	28.4	18.8
	29.0	20.1	13.3	21.2	14.0	22.2	14.7	23.0	15.2	23.8	15.7	24.5	16.2	25.2	16.6	26.7	17.6	27.9	18.4
	31.0	19.7	13.0	20.7	13.7	21.8	14.4	22.5	14.9	23.3	15.4	24.0	15.9	24.7	16.3	26.1	17.3	27.3	18.1
	33.0	19.3	12.8	20.3	13.4	21.3	14.1	22.1	14.6	22.8	15.1	23.5	15.5	24.2	16.0	25.6	16.9	26.8	17.7
	35.0	18.9	12.5	19.9	13.1	20.9	13.8	21.6	14.3	22.3	14.8	23.0	15.2	23.7	15.6	25.1	16.6	26.2	17.3
	37.0	18.5	12.2	19.5	12.9	20.4	13.5	21.1	14.0	21.9	14.4	22.5	14.9	23.2	15.3	24.5	16.2	25.6	16.9
39.0	18.1	12.0	19.0	12.6	20.0	13.2	20.7	13.7	21.4	14.1	22.0	14.5	22.6	15.0	24.0	15.8	25.1	16.6	

TC:Total Capacity [kW]
SHC:Sensible Heat Capacity [kW]

Digital Inverter 8,10HP Sensible Heat Capacity: RAV-SM*MUT-E**

Outdoor unit size		indoor air temp.																		
		outdoor air temp. CDB	14.0CWB 20.0CDB		15.0CWB 21.5CDB		16.0CWB 23.0CDB		17.0CWB 24.5CDB		18.0CWB 26.0CDB		19.0CWB 27.0CDB		20.0CWB 28.0CDB		22.0CWB 30.0CDB		24.0CWB 32.0CDB	
			TC	SHC	TC	SHC	TC	SHC	TC	SHC	TC	SHC	TC	SHC	TC	SHC	TC	SHC	TC	SHC
2244	10.0	20.8	15.2	21.9	16.0	23.0	16.8	23.8	17.4	24.6	18.0	25.4	18.5	26.1	19.0	27.6	20.2	28.9	21.1	
	12.0	20.5	14.9	21.5	15.7	22.6	16.5	23.4	17.1	24.2	17.7	24.9	18.2	25.6	18.7	27.1	19.8	28.4	20.7	
	14.0	20.1	14.7	21.2	15.5	22.2	16.2	23.0	16.8	23.8	17.4	24.5	17.9	25.2	18.4	26.7	19.5	27.9	20.4	
	16.0	19.8	14.4	20.8	15.2	21.8	15.9	22.6	16.5	23.4	17.1	24.1	17.6	24.8	18.1	26.2	19.1	27.4	20.0	
	18.0	19.4	14.2	20.4	14.9	21.4	15.7	22.2	16.2	23.0	16.8	23.6	17.3	24.3	17.7	25.7	18.8	26.9	19.7	
	20.0	19.1	13.9	20.1	14.6	21.1	15.4	21.8	15.9	22.5	16.5	23.2	16.9	23.9	17.4	25.3	18.5	26.4	19.3	
	21.0	18.9	13.8	19.9	14.5	20.9	15.2	21.6	15.8	22.3	16.3	23.0	16.8	23.7	17.3	25.0	18.3	26.2	19.1	
	23.0	18.5	13.5	19.5	14.2	20.5	14.9	21.2	15.5	21.9	16.0	22.6	16.5	23.2	16.9	24.6	17.9	25.7	18.8	
	25.0	18.2	13.3	19.1	14.0	20.1	14.7	20.8	15.2	21.5	15.7	22.1	16.2	22.8	16.6	24.1	17.6	25.2	18.4	
	27.0	17.8	13.0	18.8	13.7	19.7	14.4	20.4	14.9	21.1	15.4	21.7	15.8	22.3	16.3	23.7	17.3	24.7	18.1	
	29.0	17.5	12.8	18.4	13.4	19.3	14.1	20.0	14.6	20.7	15.1	21.3	15.5	21.9	16.0	23.2	16.9	24.2	17.7	
	31.0	17.1	12.5	18.0	13.2	18.9	13.8	19.6	14.3	20.3	14.8	20.9	15.2	21.5	15.7	22.7	16.6	23.8	17.3	
	33.0	16.8	12.2	17.7	12.9	18.5	13.5	19.2	14.0	19.8	14.5	20.4	14.9	21.0	15.3	22.3	16.2	23.3	17.0	
	35.0	16.4	12.0	17.3	12.6	18.1	13.2	18.8	13.7	19.4	14.2	20.0	14.6	20.6	15.0	21.8	15.9	22.8	16.6	
	37.0	16.1	11.7	16.9	12.3	17.8	13.0	18.4	13.4	19.0	13.9	19.6	14.3	20.1	14.7	21.3	15.6	22.3	16.3	
39.0	15.7	11.5	16.5	12.1	17.4	12.7	18.0	13.1	18.6	13.6	19.1	14.0	19.7	14.4	20.9	15.2	21.8	15.9		

TC:Total Capacity [kW]
SHC:Sensible Heat Capacity [kW]

Digital Inverter 8,10HP Sensible Heat Capacity: RAV-SM*SDT-E**

Outdoor unit size		indoor air temp.																		
		outdoor air temp. CDB	14.0CWB 20.0CDB		15.0CWB 21.5CDB		16.0CWB 23.0CDB		17.0CWB 24.5CDB		18.0CWB 26.0CDB		19.0CWB 27.0CDB		20.0CWB 28.0CDB		22.0CWB 30.0CDB		24.0CWB 32.0CDB	
			TC	SHC	TC	SHC	TC	SHC	TC	SHC	TC	SHC	TC	SHC	TC	SHC	TC	SHC	TC	SHC
2244	10.0	20.8	14.2	21.9	14.9	23.0	15.6	23.8	16.2	24.6	16.7	25.4	17.2	26.1	17.7	27.6	18.8	28.9	19.6	
	12.0	20.5	13.9	21.5	14.6	22.6	15.4	23.4	15.9	24.2	16.5	24.9	16.9	25.6	17.4	27.1	18.5	28.4	19.3	
	14.0	20.1	13.7	21.2	14.4	22.2	15.1	23.0	15.6	23.8	16.2	24.5	16.7	25.2	17.1	26.7	18.1	27.9	19.0	
	16.0	19.8	13.4	20.8	14.1	21.8	14.8	22.6	15.4	23.4	15.9	24.1	16.4	24.8	16.8	26.2	17.8	27.4	18.6	
	18.0	19.4	13.2	20.4	13.9	21.4	14.6	22.2	15.1	23.0	15.6	23.6	16.1	24.3	16.5	25.7	17.5	26.9	18.3	
	20.0	19.1	13.0	20.1	13.6	21.1	14.3	21.8	14.8	22.5	15.3	23.2	15.8	23.9	16.2	25.3	17.2	26.4	18.0	
	21.0	18.9	12.8	19.9	13.5	20.9	14.2	21.6	14.7	22.3	15.2	23.0	15.6	23.7	16.1	25.0	17.0	26.2	17.8	
	23.0	18.5	12.6	19.5	13.3	20.5	13.9	21.2	14.4	21.9	14.9	22.6	15.3	23.2	15.8	24.6	16.7	25.7	17.5	
	25.0	18.2	12.4	19.1	13.0	20.1	13.7	20.8	14.1	21.5	14.6	22.1	15.1	22.8	15.5	24.1	16.4	25.2	17.2	
	27.0	17.8	12.1	18.8	12.8	19.7	13.4	20.4	13.9	21.1	14.3	21.7	14.8	22.3	15.2	23.7	16.1	24.7	16.8	
	29.0	17.5	11.9	18.4	12.5	19.3	13.1	20.0	13.6	20.7	14.1	21.3	14.5	21.9	14.9	23.2	15.8	24.2	16.5	
	31.0	17.1	11.6	18.0	12.3	18.9	12.9	19.6	13.3	20.3	13.8	20.9	14.2	21.5	14.6	22.7	15.4	23.8	16.2	
	33.0	16.8	11.4	17.7	12.0	18.5	12.6	19.2	13.0	19.8	13.5	20.4	13.9	21.0	14.3	22.3	15.1	23.3	15.8	
	35.0	16.4	11.2	17.3	11.8	18.1	12.3	18.8	12.8	19.4	13.2	20.0	13.6	20.6	14.0	21.8	14.8	22.8	15.5	
	37.0	16.1	10.9	16.9	11.5	17.8	12.1	18.4	12.5	19.0	12.9	19.6	13.3	20.1	13.7	21.3	14.5	22.3	15.2	
39.0	15.7	10.7	16.5	11.3	17.4	11.8	18.0	12.2	18.6	12.6	19.1	13.0	19.7	13.4	20.9	14.2	21.8	14.8		

TC:Total Capacity [kW]
SHC:Sensible Heat Capacity [kW]

7 Part Load Performance

7-1. Indoor unit: 4-way cassette (Twin, Triple, W-Twin) Outdoor unit: RAV-SM2244AT8-E, RAV-SM2244AT7

Cooling

Outdoor temperature (°C)		Load (%)									
		100	90	80	70	60	50	40	30	20	10
46	Q	15880*	15880	14110	12350	10580	8820	8640	8640	8640	8640
	W	6130	6130	5120	4220	3420	2690	2670	2670	2670	2670
40	Q	18920	17030	15140	13240	11350	9460	9270	9270	9270	9270
	W	6700	5650	4730	3900	3150	2480	2470	2470	2470	2470
35	Q	20000	18000	16000	14000	12000	10000	9800	9800	9800	9800
	W	6240	5269	4404	3631	2939	2310	2300	2300	2300	2300
30	Q	21080	18970	16860	14760	12650	10540	10330	10330	10330	10330
	W	5780	4880	4080	3370	2720	2140	2130	2130	2130	2130
25	Q	22140	19930	17710	15500	13280	11070	10850	10850	10850	10850
	W	5340	4510	3770	3110	2520	1980	1970	1970	1970	1970
20	Q	23220	20900	18580	16250	13930	11610	11380	11380	11380	11380
	W	4900	4140	3460	2850	2310	1810	1810	1810	1810	1810

Heating

Outdoor temperature (°C)		Load (%)									
		100	90	80	70	60	50	40	30	20	10
15	Q	27010	24310	21610	18910	16210	13510	11820	11820	11820	11820
	W	6420	5400	4470	3640	2890	2220	2100	2100	2100	2100
10	Q	24530	22080	19620	17170	14720	12260	10730	10730	10730	10730
	W	6080	5120	4230	3450	2740	2100	1990	1990	1990	1990
7	Q	22400	20160	17920	15680	13440	11200	9800	9800	9800	9800
	W	5820	4900	4050	3300	2620	2010	1900	1900	1900	1900
5	Q	20900	18810	16720	14630	12540	10450	9140	9140	9140	9140
	W	5640	4750	3920	3200	2540	1950	1840	1840	1840	1840
2	Q	18730	16850	14980	13110	11240	9360	8190	8190	8190	8190
	W	5370	4520	3730	3040	2420	1850	1750	1750	1750	1750
0	Q	14630	13160	11700	10240	8780	7310	6400	6400	6400	6400
	W	4770	4010	3320	2700	2150	1650	1560	1560	1560	1560
-5	Q	14630	13160	11700	10240	8780	7310	6400	6400	6400	6400
	W	4770	4010	3320	2700	2150	1650	1560	1560	1560	1560
-7	Q	13750	12380	11260	11600	9950	8290	6630	6020	6020	6020
	W	4620	3890	3080	2620	2080	1600	1510	1510	1510	1510
-10	Q	12600	11340	10080	8820	7560	7590	6070	5510	5510	5510
	W	4430	3730	3080	2510	1990	1530	1450	1450	1450	1450
-15	Q	10620	9560	8490	7430	6370	5310	4650	4650	4650	4650
	W	4180	3520	2910	2370	1880	1440	1360	1360	1360	1360
-20	Q	8690	7820	6950	6080	5210	4350	3800	3800	3800	3800
	W	3930	3310	2730	2230	1770	1360	1280	1280	1280	1280

*: Protection operation

7-2. Indoor unit: 4-way cassette (Twin, Triple, W-Twin) Outdoor unit: RAV-SM2804AT8-E, RAV-SM2804AT7

Cooling

Outdoor temperature (°C)		Load (%)									
		100	90	80	70	60	50	40	30	20	10
46	Q	16010*	16010*	16010	14200	12170	10140	8640	8640	8640	8640
	W	6170	6170	6170	4870	3740	2790	2670	2670	2670	2670
40	Q	21760	19580	17410	15230	13050	10880	9270	9270	9270	9270
	W	8790	7130	5710	4490	3450	2570	2470	2470	2470	2470
35	Q	23000	20700	18400	16100	13800	11500	9800	9800	9800	9800
	W	8190	6643	5318	4184	3220	2400	2300	2300	2300	2300
30	Q	24240	21820	19390	16970	14550	12120	10330	10330	10330	10330
	W	7590	6160	4930	3880	2980	2220	2130	2130	2130	2130
25	Q	25460	22910	20370	17820	15280	12730	10850	10850	10850	10850
	W	7010	5690	4550	3580	2760	2050	1970	1970	1970	1970
20	Q	26700	24030	21360	18690	16020	13350	11380	11380	11380	11380
	W	6430	5210	4170	3280	2530	1880	1810	1810	1810	1810

Heating

Outdoor temperature (°C)		Load (%)									
		100	90	80	70	60	50	40	30	20	10
15	Q	32560	29300	26050	22790	19540	16280	13020	11820	11820	11820
	W	8250	6940	5750	4680	3720	2860	2250	2100	2100	2100
10	Q	29570	26610	23650	20700	17740	14780	11830	10730	10730	10730
	W	7820	6570	5440	4430	3520	2710	2130	1990	1990	1990
7	Q	27000	24300	21600	18900	16200	13500	10800	9800	9800	9800
	W	7480	6290	5210	4240	3370	2590	2040	1900	1900	1900
5	Q	25190	22670	20150	17630	15110	12600	10080	9140	9140	9140
	W	7250	6100	5050	4110	3270	2510	1980	1840	1840	1840
2	Q	22570	20310	18060	15800	13540	11290	9030	8190	8190	8190
	W	6900	5800	4800	3910	3110	2390	1880	1750	1750	1750
0	Q	17630	15870	14100	12340	10580	8820	7050	6400	6400	6400
	W	6130	5150	4270	3470	2760	2120	1670	1560	1560	1560
-5	Q	17630	15870	14100	12340	10580	8820	7050	6400	6400	6400
	W	6130	5150	4270	3470	2760	2120	1670	1560	1560	1560
-7	Q	16580	14920	13260	11600	9950	8290	6630	6020	6020	6020
	W	5940	4990	4140	3370	2680	2060	1620	1510	1510	1510
-10	Q	15180	13670	12150	10630	9110	7590	6070	5510	5510	5510
	W	5690	4790	3960	3230	2560	1970	1550	1450	1450	1450
-15	Q	12800	11520	10240	8960	7680	6400	5120	4650	4650	4650
	W	5370	4510	3740	3040	2420	1860	1460	1360	1360	1360
-20	Q	10480	9430	8380	7330	6290	5240	4190	3800	3800	3800
	W	5050	4250	3520	2860	2270	1750	1380	1280	1280	1280

*: Protection operation

7-3. Indoor unit: Duct (Twin, Triple, W-Twin) Outdoor unit: RAV-SM2244AT8-E, RAV-SM2244AT7

Cooling

Outdoor temperature (°C)		Load (%)									
		100	90	80	70	60	50	40	30	20	10
46	Q	14820*	14820	14110	12350	10580	8820	8640	8640	8640	8640
	W	6140	6140	5620	4540	3600	2770	2760	2760	2760	2760
40	Q	18920	17030	15140	13240	11350	9460	9270	9270	9270	9270
	W	7650	6340	5190	4190	3320	2560	2550	2550	2550	2550
35	Q	20000	18000	16000	14000	12000	10000	9800	9800	9800	9800
	W	7120	5901	4837	3905	3093	2380	2370	2370	2370	2370
30	Q	21080	18970	16860	14760	12650	10540	10330	10330	10330	10330
	W	6620	5490	4500	3630	2880	2210	2200	2200	2200	2200
25	Q	22140	19930	17710	15500	13280	11070	10850	10850	10850	10850
	W	6100	5060	4140	3350	2650	2040	2030	2030	2030	2030
20	Q	23220	20900	18580	16250	13930	11610	11380	11380	11380	11380
	W	5590	4630	3800	3070	2430	1870	1860	1860	1860	1860

Heating

Outdoor temperature (°C)		Load (%)									
		100	90	80	70	60	50	40	30	20	10
15	Q	27010	24310	21610	18910	16210	13510	11820	11820	11820	11820
	W	7060	5890	4830	3880	3040	2300	2180	2180	2180	2180
10	Q	24530	22080	19620	17170	14720	12260	10730	10730	10730	10730
	W	6690	5580	4580	3680	2880	2180	2070	2070	2070	2070
7	Q	22400	20160	17920	15680	13440	11200	9800	9800	9800	9800
	W	6400	5340	4380	3520	2760	2090	1980	1980	1980	1980
5	Q	20900	18810	16720	14630	12540	10450	9140	9140	9140	9140
	W	6200	5170	4240	3410	2670	2030	1920	1920	1920	1920
2	Q	18730	16850	14980	13110	11240	9360	8190	8190	8190	8190
	W	5900	4920	4040	3250	2540	1930	1830	1830	1830	1830
0	Q	14630	13160	11700	10240	8780	7310	6400	6400	6400	6400
	W	5240	4370	3590	2880	2260	1710	1620	1620	1620	1620
-5	Q	14630	13160	11700	10240	8780	7310	6400	6400	6400	6400
	W	5240	4370	3590	2880	2260	1710	1620	1620	1620	1620
-7	Q	13750	12380	11000	9630	8250	6880	6020	6020	6020	6020
	W	5080	4240	3480	2790	2190	1660	1570	1570	1570	1570
-10	Q	12600	11340	10080	8820	7560	6300	5510	5510	5510	5510
	W	4870	4060	3330	2680	2100	1590	1510	1510	1510	1510
-15	Q	10620	9560	8490	7430	6370	5310	4650	4650	4650	4650
	W	4590	3830	3140	2530	1980	1500	1420	1420	1420	1420
-20	Q	8690	7820	6950	6080	5210	4350	3800	3800	3800	3800
	W	4320	3600	2960	2380	1860	1410	1340	1340	1340	1340

*: Protection operation

**7-4. Indoor unit: Duct (Twin, Triple, W-Twin)
Outdoor unit: RAV-SM2804AT8-E, RAV-SM2804AT7**

Cooling

Outdoor temperature (°C)		Load (%)									
		100	90	80	70	60	50	40	30	20	10
46	Q	15270*	15270*	15270	14200	12170	10140	8640	8640	8640	8640
	W	6190	6190	6190	5350	4010	2900	2760	2760	2760	2760
40	Q	21760	19580	17410	15230	13050	10880	9270	9270	9270	9270
	W	10260	8180	6420	4940	3700	2670	2550	2550	2550	2550
35	Q	23000	20700	18400	16100	13800	11500	9800	9800	9800	9800
	W	9550	7615	5979	4599	3447	2490	2370	2370	2370	2370
30	Q	24240	21820	19390	16970	14550	12120	10330	10330	10330	10330
	W	8880	7080	5560	4280	3210	2320	2200	2200	2200	2200
25	Q	25460	22910	20370	17820	15280	12730	10850	10850	10850	10850
	W	8180	6530	5120	3940	2950	2130	2030	2030	2030	2030
20	Q	26700	24030	21360	18690	16020	13350	11380	11380	11380	11380
	W	7500	5980	4690	3610	2710	1950	1860	1860	1860	1860

Heating

Outdoor temperature (°C)		Load (%)									
		100	90	80	70	60	50	40	30	20	10
15	Q	32560	29300	26050	22790	19540	16280	13020	11820	11820	11820
	W	8730	7340	6090	4950	3940	3030	2380	2180	2180	2180
10	Q	29570	26610	23650	20700	17740	14780	11830	10730	10730	10730
	W	8280	6960	5770	4690	3730	2870	2260	2070	2070	2070
7	Q	27000	24300	21600	18900	16200	13500	10800	9800	9800	9800
	W	7920	6660	5520	4490	3570	2750	2160	1980	1980	1980
5	Q	25190	22670	20150	17630	15110	12600	10080	9140	9140	9140
	W	7670	6450	5350	4350	3460	2660	2090	1920	1920	1920
2	Q	22570	20310	18060	15800	13540	11290	9030	8190	8190	8190
	W	7300	6140	5090	4140	3290	2540	1990	1830	1830	1830
0	Q	17630	15870	14100	12340	10580	8820	7050	6400	6400	6400
	W	6490	5450	4520	3680	2920	2250	1770	1620	1620	1620
-5	Q	17630	15870	14100	12340	10580	8820	7050	6400	6400	6400
	W	6490	5450	4520	3680	2920	2250	1770	1620	1620	1620
-7	Q	16580	14920	13260	11600	9950	8290	6630	6020	6020	6020
	W	6290	5290	4380	3570	2830	2180	1720	1570	1570	1570
-10	Q	15180	13670	12150	10630	9110	7590	6070	5510	5510	5510
	W	6030	5070	4200	3420	2720	2090	1640	1510	1510	1510
-15	Q	12800	11520	10240	8960	7680	6400	5120	4650	4650	4650
	W	5680	4780	3960	3220	2560	1970	1550	1420	1420	1420
-20	Q	10480	9430	8380	7330	6290	5240	4190	3800	3800	3800
	W	5350	4500	3730	3030	2410	1860	1460	1340	1340	1340

*: Protection operation

**7-5. Indoor unit: Ceiling (Twin, Triple, W-Twin)
Outdoor unit: RAV-SM2244AT8-E, RAV-SM2244AT7**

Cooling

Outdoor temperature (°C)		Load (%)									
		100	90	80	70	60	50	40	30	20	10
46	Q	14820*	14820	14110	12350	10580	8820	8640	8640	8640	8640
	W	6140	6140	5620	4540	3600	2770	2760	2760	2760	2760
40	Q	18920	17030	15140	13240	11350	9460	9270	9270	9270	9270
	W	7650	6340	5190	4190	3320	2560	2550	2550	2550	2550
35	Q	20000	18000	16000	14000	12000	10000	9800	9800	9800	9800
	W	7120	5901	4837	3905	3093	2380	2370	2370	2370	2370
30	Q	21080	18970	16860	14760	12650	10540	10330	10330	10330	10330
	W	6620	5490	4500	3630	2880	2210	2200	2200	2200	2200
25	Q	22140	19930	17710	15500	13280	11070	10850	10850	10850	10850
	W	6100	5060	4140	3350	2650	2040	2030	2030	2030	2030
20	Q	23220	20900	18580	16250	13930	11610	11380	11380	11380	11380
	W	5590	4630	3800	3070	2430	1870	1860	1860	1860	1860

Heating

Outdoor temperature (°C)		Load (%)									
		100	90	80	70	60	50	40	30	20	10
15	Q	27010	24310	21610	18910	16210	13510	11820	11820	11820	11820
	W	7060	5890	4830	3880	3040	2300	2180	2180	2180	2180
10	Q	24530	22080	19620	17170	14720	12260	10730	10730	10730	10730
	W	6690	5580	4580	3680	2880	2180	2070	2070	2070	2070
7	Q	22400	20160	17920	15680	13440	11200	9800	9800	9800	9800
	W	6400	5340	4380	3520	2760	2090	1980	1980	1980	1980
5	Q	20900	18810	16720	14630	12540	10450	9140	9140	9140	9140
	W	6200	5170	4240	3410	2670	2030	1920	1920	1920	1920
2	Q	18730	16850	14980	13110	11240	9360	8190	8190	8190	8190
	W	5900	4920	4040	3250	2540	1930	1830	1830	1830	1830
0	Q	14630	13160	11700	10240	8780	7310	6400	6400	6400	6400
	W	5240	4370	3590	2880	2260	1710	1620	1620	1620	1620
-5	Q	14630	13160	11700	10240	8780	7310	6400	6400	6400	6400
	W	5240	4370	3590	2880	2260	1710	1620	1620	1620	1620
-7	Q	13750	12380	11000	9630	8250	6880	6020	6020	6020	6020
	W	5080	4240	3480	2790	2190	1660	1570	1570	1570	1570
-10	Q	12600	11340	10080	8820	7560	6300	5510	5510	5510	5510
	W	4870	4060	3330	2680	2100	1590	1510	1510	1510	1510
-15	Q	10620	9560	8490	7430	6370	5310	4650	4650	4650	4650
	W	4590	3830	3140	2530	1980	1500	1420	1420	1420	1420
-20	Q	8690	7820	6950	6080	5210	4350	3800	3800	3800	3800
	W	4320	3600	2960	2380	1860	1410	1340	1340	1340	1340

*: Protection operation

**7-6. Indoor unit: Ceiling (Twin, Triple, W-Twin)
Outdoor unit: RAV-SM2804AT8-E, RAV-SM2804AT7**

Cooling

Outdoor temperature (°C)		Load (%)									
		100	90	80	70	60	50	40	30	20	10
46	Q	15270*	15270*	15270	14200	12170	10140	8640	8640	8640	8640
	W	6190	6190	6190	5350	4010	2900	2760	2760	2760	2760
40	Q	21760	19580	17410	15230	13050	10880	9270	9270	9270	9270
	W	10260	8180	6420	4940	3700	2670	2550	2550	2550	2550
35	Q	23000	20700	18400	16100	13800	11500	9800	9800	9800	9800
	W	9550	7615	5979	4599	3447	2490	2370	2370	2370	2370
30	Q	24240	21820	19390	16970	14550	12120	10330	10330	10330	10330
	W	8880	7080	5560	4280	3210	2320	2200	2200	2200	2200
25	Q	25460	22910	20370	17820	15280	12730	10850	10850	10850	10850
	W	8180	6530	5120	3940	2950	2130	2030	2030	2030	2030
20	Q	26700	24030	21360	18690	16020	13350	11380	11380	11380	11380
	W	7500	5980	4690	3610	2710	1950	1860	1860	1860	1860

Heating

Outdoor temperature (°C)		Load (%)									
		100	90	80	70	60	50	40	30	20	10
15	Q	32560	29300	26050	22790	19540	16280	13020	11820	11820	11820
	W	8730	7340	6090	4950	3940	3030	2380	2180	2180	2180
10	Q	29570	26610	23650	20700	17740	14780	11830	10730	10730	10730
	W	8280	6960	5770	4690	3730	2870	2260	2070	2070	2070
7	Q	27000	24300	21600	18900	16200	13500	10800	9800	9800	9800
	W	7920	6660	5520	4490	3570	2750	2160	1980	1980	1980
5	Q	25190	22670	20150	17630	15110	12600	10080	9140	9140	9140
	W	7670	6450	5350	4350	3460	2660	2090	1920	1920	1920
2	Q	22570	20310	18060	15800	13540	11290	9030	8190	8190	8190
	W	7300	6140	5090	4140	3290	2540	1990	1830	1830	1830
0	Q	17630	15870	14100	12340	10580	8820	7050	6400	6400	6400
	W	6490	5450	4520	3680	2920	2250	1770	1620	1620	1620
-5	Q	17630	15870	14100	12340	10580	8820	7050	6400	6400	6400
	W	6490	5450	4520	3680	2920	2250	1770	1620	1620	1620
-7	Q	16580	14920	13260	11600	9950	8290	6630	6020	6020	6020
	W	6290	5290	4380	3570	2830	2180	1720	1570	1570	1570
-10	Q	15180	13670	12150	10630	9110	7590	6070	5510	5510	5510
	W	6030	5070	4200	3420	2720	2090	1640	1510	1510	1510
-15	Q	12800	11520	10240	8960	7680	6400	5120	4650	4650	4650
	W	5680	4780	3960	3220	2560	1970	1550	1420	1420	1420
-20	Q	10480	9430	8380	7330	6290	5240	4190	3800	3800	3800
	W	5350	4500	3730	3030	2410	1860	1460	1340	1340	1340

*: Protection operation

7-7. Indoor unit: High wall (Triple, W-Twin)
Outdoor unit: RAV-SM2244AT8-E, RAV-SM2244AT7

Cooling

Outdoor temperature (°C)		Load (%)									
		100	90	80	70	60	50	40	30	20	10
46	Q	14820*	14820	14110	12350	10580	8820	8640	8640	8640	8640
	W	6140	6140	5620	4540	3600	2770	2760	2760	2760	2760
40	Q	18920	17030	15140	13240	11350	9460	9270	9270	9270	9270
	W	7650	6340	5190	4190	3320	2560	2550	2550	2550	2550
35	Q	20000	18000	16000	14000	12000	10000	9800	9800	9800	9800
	W	7120	5901	4837	3905	3093	2380	2370	2370	2370	2370
30	Q	21080	18970	16860	14760	12650	10540	10330	10330	10330	10330
	W	6620	5490	4500	3630	2880	2210	2200	2200	2200	2200
25	Q	22140	19930	17710	15500	13280	11070	10850	10850	10850	10850
	W	6100	5060	4140	3350	2650	2040	2030	2030	2030	2030
20	Q	23220	20900	18580	16250	13930	11610	11380	11380	11380	11380
	W	5590	4630	3800	3070	2430	1870	1860	1860	1860	1860

Heating

Outdoor temperature (°C)		Load (%)									
		100	90	80	70	60	50	40	30	20	10
15	Q	27010	24310	21610	18910	16210	13510	11820	11820	11820	11820
	W	7060	5890	4830	3880	3040	2300	2180	2180	2180	2180
10	Q	24530	22080	19620	17170	14720	12260	10730	10730	10730	10730
	W	6690	5580	4580	3680	2880	2180	2070	2070	2070	2070
7	Q	22400	20160	17920	15680	13440	11200	9800	9800	9800	9800
	W	6400	5340	4380	3520	2760	2090	1980	1980	1980	1980
5	Q	20900	18810	16720	14630	12540	10450	9140	9140	9140	9140
	W	6200	5170	4240	3410	2670	2030	1920	1920	1920	1920
2	Q	18730	16850	14980	13110	11240	9360	8190	8190	8190	8190
	W	5900	4920	4040	3250	2540	1930	1830	1830	1830	1830
0	Q	14630	13160	11700	10240	8780	7310	6400	6400	6400	6400
	W	5240	4370	3590	2880	2260	1710	1620	1620	1620	1620
-5	Q	14630	13160	11700	10240	8780	7310	6400	6400	6400	6400
	W	5240	4370	3590	2880	2260	1710	1620	1620	1620	1620
-7	Q	13750	12380	11000	9630	8250	6880	6020	6020	6020	6020
	W	5080	4240	3480	2790	2190	1660	1570	1570	1570	1570
-10	Q	12600	11340	10080	8820	7560	6300	5510	5510	5510	5510
	W	4870	4060	3330	2680	2100	1590	1510	1510	1510	1510
-15	Q	10620	9560	8490	7430	6370	5310	4650	4650	4650	4650
	W	4590	3830	3140	2530	1980	1500	1420	1420	1420	1420
-20	Q	8690	7820	6950	6080	5210	4350	3800	3800	3800	3800
	W	4320	3600	2960	2380	1860	1410	1340	1340	1340	1340

*: Protection operation

7-8. Indoor unit: High wall (Triple, W-Twin)
Outdoor unit: RAV-SM2804AT8-E, RAV-SM2804AT7

Cooling

Outdoor temperature (°C)		Load (%)									
		100	90	80	70	60	50	40	30	20	10
46	Q	15270*	15270*	15270	14200	12170	10140	8640	8640	8640	8640
	W	6190	6190	6190	5350	4010	2900	2760	2760	2760	2760
40	Q	21760	19580	17410	15230	13050	10880	9270	9270	9270	9270
	W	10260	8180	6420	4940	3700	2670	2550	2550	2550	2550
35	Q	23000	20700	18400	16100	13800	11500	9800	9800	9800	9800
	W	9550	7615	5979	4599	3447	2490	2370	2370	2370	2370
30	Q	24240	21820	19390	16970	14550	12120	10330	10330	10330	10330
	W	8880	7080	5560	4280	3210	2320	2200	2200	2200	2200
25	Q	25460	22910	20370	17820	15280	12730	10850	10850	10850	10850
	W	8180	6530	5120	3940	2950	2130	2030	2030	2030	2030
20	Q	26700	24030	21360	18690	16020	13350	11380	11380	11380	11380
	W	7500	5980	4690	3610	2710	1950	1860	1860	1860	1860

Heating

Outdoor temperature (°C)		Load (%)									
		100	90	80	70	60	50	40	30	20	10
15	Q	32560	29300	26050	22790	19540	16280	13020	11820	11820	11820
	W	8730	7340	6090	4950	3940	3030	2380	2180	2180	2180
10	Q	29570	26610	23650	20700	17740	14780	11830	10730	10730	10730
	W	8280	6960	5770	4690	3730	2870	2260	2070	2070	2070
7	Q	27000	24300	21600	18900	16200	13500	10800	9800	9800	9800
	W	7920	6660	5520	4490	3570	2750	2160	1980	1980	1980
5	Q	25190	22670	20150	17630	15110	12600	10080	9140	9140	9140
	W	7670	6450	5350	4350	3460	2660	2090	1920	1920	1920
2	Q	22570	20310	18060	15800	13540	11290	9030	8190	8190	8190
	W	7300	6140	5090	4140	3290	2540	1990	1830	1830	1830
0	Q	17630	15870	14100	12340	10580	8820	7050	6400	6400	6400
	W	6490	5450	4520	3680	2920	2250	1770	1620	1620	1620
-5	Q	17630	15870	14100	12340	10580	8820	7050	6400	6400	6400
	W	6490	5450	4520	3680	2920	2250	1770	1620	1620	1620
-7	Q	16580	14920	13260	11600	9950	8290	6630	6020	6020	6020
	W	6290	5290	4380	3570	2830	2180	1720	1570	1570	1570
-10	Q	15180	13670	12150	10630	9110	7590	6070	5510	5510	5510
	W	6030	5070	4200	3420	2720	2090	1640	1510	1510	1510
-15	Q	12800	11520	10240	8960	7680	6400	5120	4650	4650	4650
	W	5680	4780	3960	3220	2560	1970	1550	1420	1420	1420
-20	Q	10480	9430	8380	7330	6290	5240	4190	3800	3800	3800
	W	5350	4500	3730	3030	2410	1860	1460	1340	1340	1340

*: Protection operation

7-9. Indoor unit: Compact 4-way cassette (W-Twin) Outdoor unit: RAV-SM2244AT8-E, RAV-SM2244AT7

Cooling

Outdoor temperature (°C)		Load (%)									
		100	90	80	70	60	50	40	30	20	10
46	Q	14820*	14820	14110	12350	10580	8820	8640	8640	8640	8640
	W	6140	6140	5620	4540	3600	2770	2760	2760	2760	2760
40	Q	18920	17030	15140	13240	11350	9460	9270	9270	9270	9270
	W	7650	6340	5190	4190	3320	2560	2550	2550	2550	2550
35	Q	20000	18000	16000	14000	12000	10000	9800	9800	9800	9800
	W	7120	5901	4837	3905	3093	2380	2370	2370	2370	2370
30	Q	21080	18970	16860	14760	12650	10540	10330	10330	10330	10330
	W	6620	5490	4500	3630	2880	2210	2200	2200	2200	2200
25	Q	22140	19930	17710	15500	13280	11070	10850	10850	10850	10850
	W	6100	5060	4140	3350	2650	2040	2030	2030	2030	2030
20	Q	23220	20900	18580	16250	13930	11610	11380	11380	11380	11380
	W	5590	4630	3800	3070	2430	1870	1860	1860	1860	1860

Heating

Outdoor temperature (°C)		Load (%)									
		100	90	80	70	60	50	40	30	20	10
15	Q	27010	24310	21610	18910	16210	13510	11820	11820	11820	11820
	W	7060	5890	4830	3880	3040	2300	2180	2180	2180	2180
10	Q	24530	22080	19620	17170	14720	12260	10730	10730	10730	10730
	W	6690	5580	4580	3680	2880	2180	2070	2070	2070	2070
7	Q	22400	20160	17920	15680	13440	11200	9800	9800	9800	9800
	W	6400	5340	4380	3520	2760	2090	1980	1980	1980	1980
5	Q	20900	18810	16720	14630	12540	10450	9140	9140	9140	9140
	W	6200	5170	4240	3410	2670	2030	1920	1920	1920	1920
2	Q	18730	16850	14980	13110	11240	9360	8190	8190	8190	8190
	W	5900	4920	4040	3250	2540	1930	1830	1830	1830	1830
0	Q	14630	13160	11700	10240	8780	7310	6400	6400	6400	6400
	W	5240	4370	3590	2880	2260	1710	1620	1620	1620	1620
-5	Q	14630	13160	11700	10240	8780	7310	6400	6400	6400	6400
	W	5240	4370	3590	2880	2260	1710	1620	1620	1620	1620
-7	Q	13750	12380	11000	9630	8250	6880	6020	6020	6020	6020
	W	5080	4240	3480	2790	2190	1660	1570	1570	1570	1570
-10	Q	12600	11340	10080	8820	7560	6300	5510	5510	5510	5510
	W	4870	4060	3330	2680	2100	1590	1510	1510	1510	1510
-15	Q	10620	9560	8490	7430	6370	5310	4650	4650	4650	4650
	W	4590	3830	3140	2530	1980	1500	1420	1420	1420	1420
-20	Q	8690	7820	6950	6080	5210	4350	3800	3800	3800	3800
	W	4320	3600	2960	2380	1860	1410	1340	1340	1340	1340

*: Protection operation

7-10. Indoor unit: Slim duct (W-Twin)**Outdoor unit: RAV-SM2244AT8-E, RAV-SM2244AT7****Cooling**

Outdoor temperature (°C)		Load (%)									
		100	90	80	70	60	50	40	30	20	10
46	Q	14820*	14820	14110	12350	10580	8820	8640	8640	8640	8640
	W	6140	6140	5620	4540	3600	2770	2760	2760	2760	2760
40	Q	18920	17030	15140	13240	11350	9460	9270	9270	9270	9270
	W	7650	6340	5190	4190	3320	2560	2550	2550	2550	2550
35	Q	20000	18000	16000	14000	12000	10000	9800	9800	9800	9800
	W	7120	5901	4837	3905	3093	2380	2370	2370	2370	2370
30	Q	21080	18970	16860	14760	12650	10540	10330	10330	10330	10330
	W	6620	5490	4500	3630	2880	2210	2200	2200	2200	2200
25	Q	22140	19930	17710	15500	13280	11070	10850	10850	10850	10850
	W	6100	5060	4140	3350	2650	2040	2030	2030	2030	2030
20	Q	23220	20900	18580	16250	13930	11610	11380	11380	11380	11380
	W	5590	4630	3800	3070	2430	1870	1860	1860	1860	1860

Heating

Outdoor temperature (°C)		Load (%)									
		100	90	80	70	60	50	40	30	20	10
15	Q	27010	24310	21610	18910	16210	13510	11820	11820	11820	11820
	W	7060	5890	4830	3880	3040	2300	2180	2180	2180	2180
10	Q	24530	22080	19620	17170	14720	12260	10730	10730	10730	10730
	W	6690	5580	4580	3680	2880	2180	2070	2070	2070	2070
7	Q	22400	20160	17920	15680	13440	11200	9800	9800	9800	9800
	W	6400	5340	4380	3520	2760	2090	1980	1980	1980	1980
5	Q	20900	18810	16720	14630	12540	10450	9140	9140	9140	9140
	W	6200	5170	4240	3410	2670	2030	1920	1920	1920	1920
2	Q	18730	16850	14980	13110	11240	9360	8190	8190	8190	8190
	W	5900	4920	4040	3250	2540	1930	1830	1830	1830	1830
0	Q	14630	13160	11700	10240	8780	7310	6400	6400	6400	6400
	W	5240	4370	3590	2880	2260	1710	1620	1620	1620	1620
-5	Q	14630	13160	11700	10240	8780	7310	6400	6400	6400	6400
	W	5240	4370	3590	2880	2260	1710	1620	1620	1620	1620
-7	Q	13750	12380	11000	9630	8250	6880	6020	6020	6020	6020
	W	5080	4240	3480	2790	2190	1660	1570	1570	1570	1570
-10	Q	12600	11340	10080	8820	7560	6300	5510	5510	5510	5510
	W	4870	4060	3330	2680	2100	1590	1510	1510	1510	1510
-15	Q	10620	9560	8490	7430	6370	5310	4650	4650	4650	4650
	W	4590	3830	3140	2530	1980	1500	1420	1420	1420	1420
-20	Q	8690	7820	6950	6080	5210	4350	3800	3800	3800	3800
	W	4320	3600	2960	2380	1860	1410	1340	1340	1340	1340

*: Protection operation

8 Sound Characteristics (NC Curve)

RAV-SM2244AT8-E, RAV-SM2244AT7

Sound pressure level (dB(A))	Cooling	Heating
	56	57

RAV-SM2804AT8-E, RAV-SM2804AT7

Sound pressure level (dB(A))	Cooling	Heating
	57	58

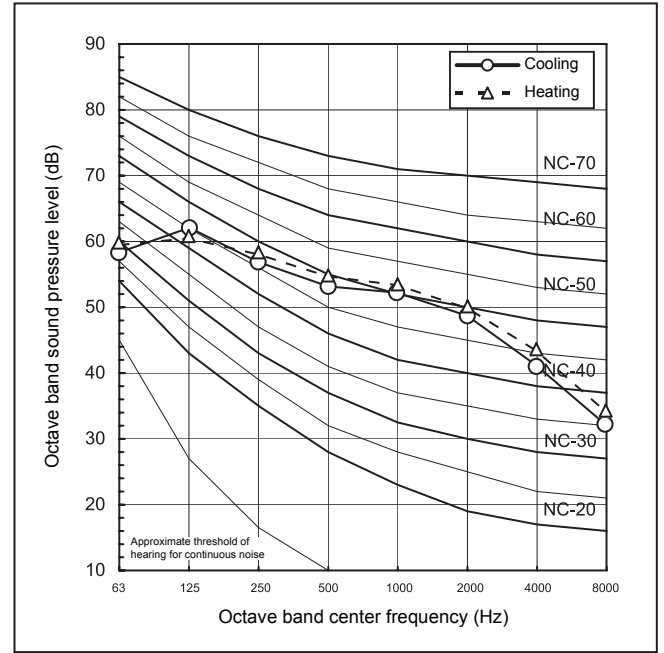
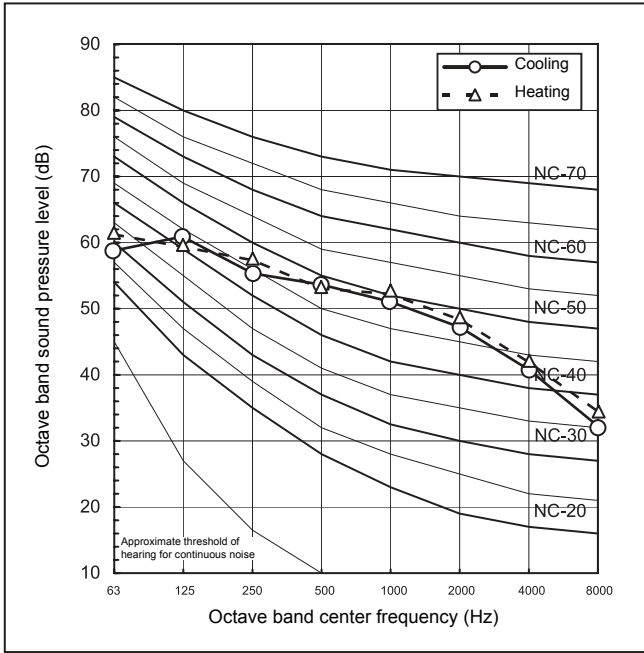

9 Capacity Correction

Connecting pipe length and lift difference between indoor units vs. capacity correction value

Cooling

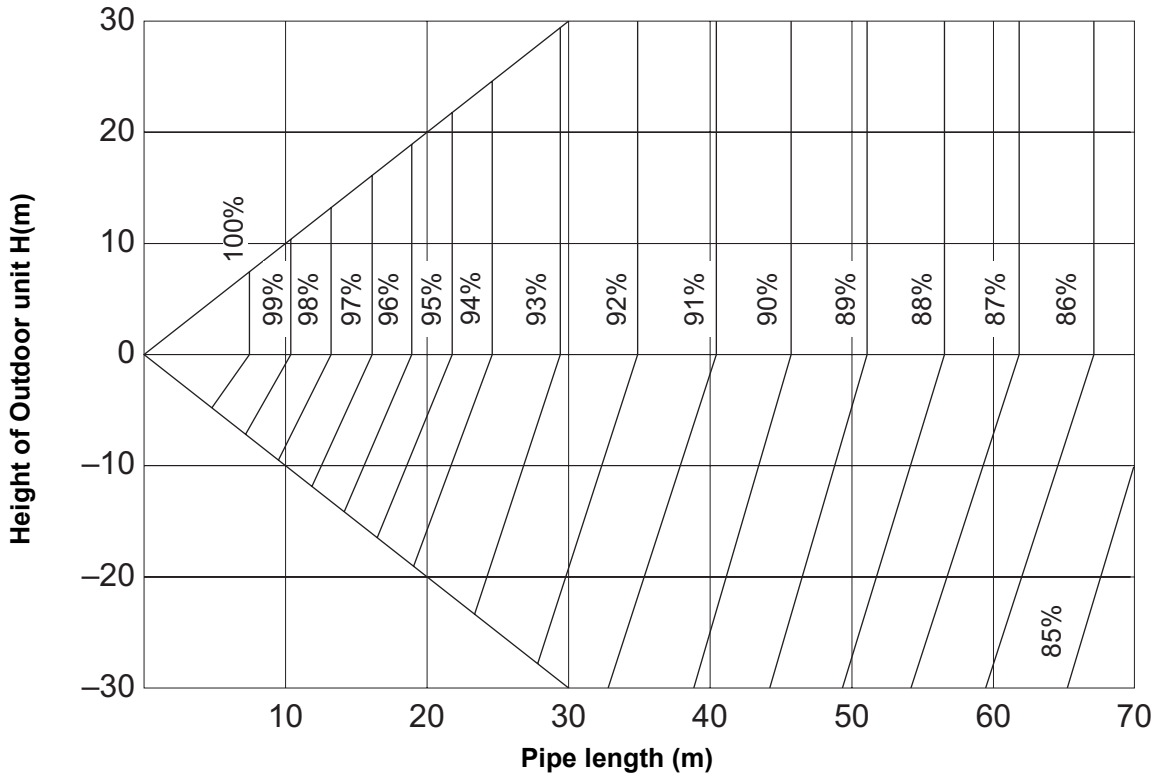

Heating

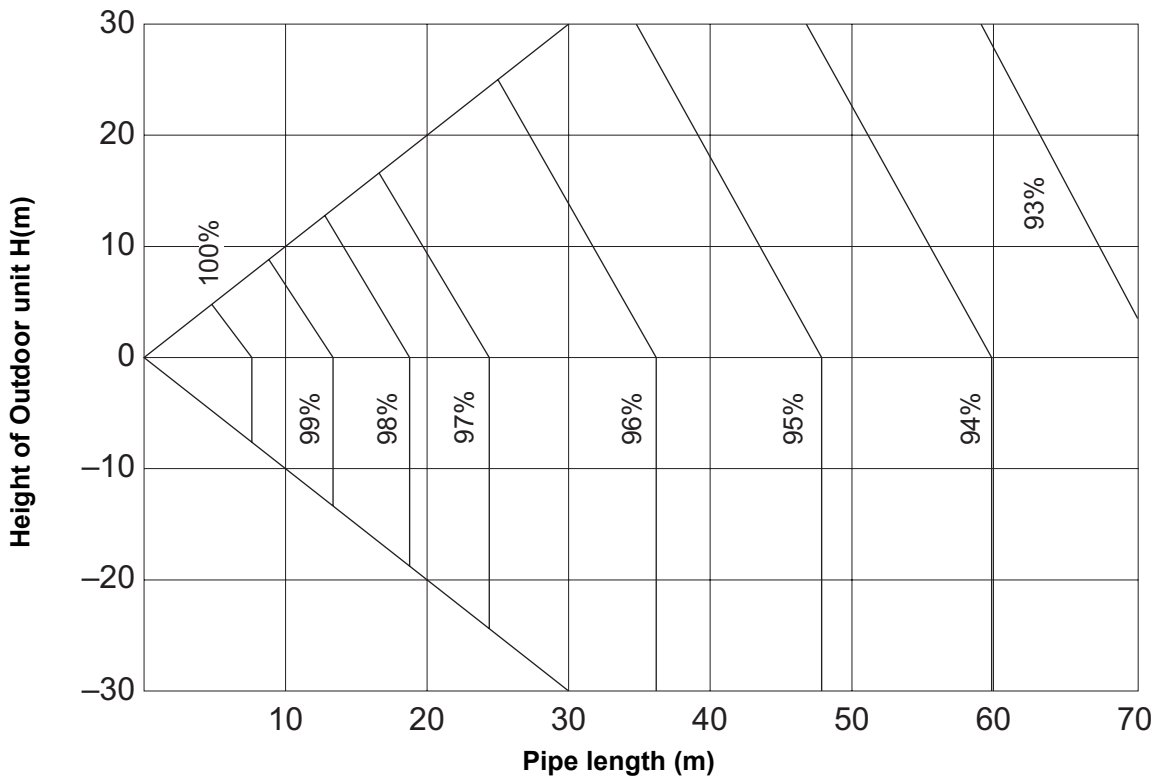

■ Refrigerant Pipe Length (Twin, Triple, Double Twin system)

Simultaneous twin, triple

Outdoor unit	Allowable pipe length (m)			Height difference (m)			Pipe diameter (mm)				Number of bent portions
	Total length • $l_1 + l_2$ • $l_1 + l_3$ • $l_1 + l_4$ Maximum	Branch piping l_2 l_3 l_4 Maximum	Branch piping • $l_3 - l_2$ • $l_4 - l_2$ • $l_4 - l_3$ Maximum	Indoor - outdoor H		Indoor - indoor (Δh)	Main pipe		Branch piping		
				Indoor unit : Upper	Outdoor unit: Upper		Gas side	Liquid side	Gas side	Liquid side	
RAV-SM2244AT8-E/ SM2244AT7	70	20	10	30	30	0.5	Ø28.6	Ø12.7	Ø15.9	Ø9.5	10 or less
RAV-SM2804AT8-E/ SM2804AT7	70	20	10	30	30	0.5	Ø28.6	Ø12.7	Ø15.9	Ø9.5	10 or less

Figure of Simultaneous twin

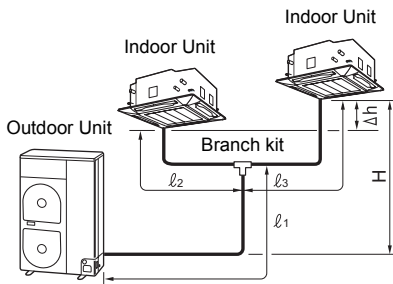
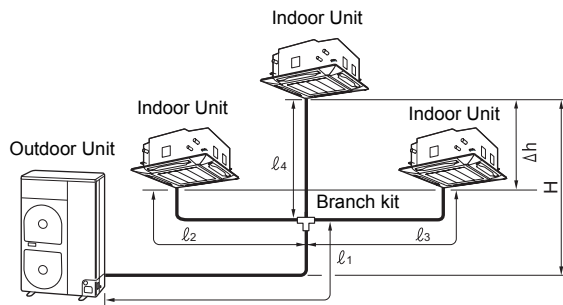

Figure of Simultaneous triple



Simultaneous double twin

Outdoor unit	Allowable pipe length (m)				Height difference (m)			Pipe diameter (mm)				Number of bent portions
	Total length • $l_1 + l_2 + l_4$ • $l_1 + l_2 + l_5$ • $l_1 + l_3 + l_6$ • $l_1 + l_3 + l_7$ Maximum	Branch piping l_4 l_5 l_6 l_7 Maximum	Branch piping • $l_4 + l_2$ • $l_5 + l_2$ • $l_6 + l_3$ • $l_7 + l_3$ Maximum	Branch piping • $(l_4 + l_2) - (l_5 + l_2)$ • $(l_4 + l_2) - (l_6 + l_3)$ • $(l_4 + l_2) - (l_7 + l_3)$ • $(l_5 + l_2) - (l_6 + l_3)$ • $(l_5 + l_2) - (l_7 + l_3)$ • $(l_6 + l_3) - (l_7 + l_3)$ Maximum	Indoor - outdoor H		Indoor - indoor (Δh)	Main pipe		Branch piping		
					Indoor unit : Upper	Outdoor unit: Upper		Gas side	Liquid side	Gas side	Liquid side	
RAV-SM2244AT8-E/ SM2244AT7	70	15	20	6	30	30	0.5	Ø28.6	Ø12.7	l_2, l_3 : Ø15.9 l_4, l_5, l_6, l_7 : Ø12.7	l_2, l_3 : Ø9.5 l_4, l_5, l_6, l_7 : Ø6.4	10 or less
RAV-SM2804AT8-E/ SM2804AT7	70	15	20	6	30	30	0.5	Ø28.6	Ø12.7	l_2 to l_7 : Ø15.9	l_2 to l_7 : Ø9.5	10 or less

Figure of Simultaneous double twin

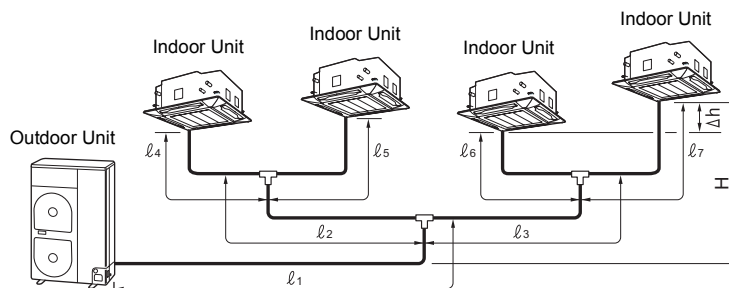

Piping connection with different diameter

- Piping connection with different diameter is possible under the below restraint conditions.
- Maximum pipe length is determined by the combination of liquid pipe diameter and gas pipe diameter.

Liquid pipe	Ø12.7 (standard)			
Gas pipe	Ø22.2 (1-size smaller)		Ø28.6 (standard)	
Pipe length	Max. pipe length	Pre-charged	Max. pipe length	Pre-charged
2244	70m	30m	70m	30m
2804	70m	30m	70m	30m

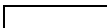
 Normal piping size

 The cooling capacity is lower since the diameter of gas pipe is smaller than standard one.















Liquid pipe	Ø15.9 (1-size larger)			
Gas pipe	Ø22.2 (1-size smaller)		Ø28.6 (standard)	
Pipe length	Max. pipe length	Pre-charged	Max. pipe length	Pre-charged
2244	50m	20m	50m	20m
2804	50m	20m	50m	20m

 The cooling capacity is lower since the diameter of gas pipe is smaller than standard one.

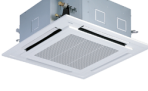
Unit	Gas pipe	Pipe length (m)	7.5 to 10	10 to 20	20 to 30	30 to 40	40 to 50	50 to 60	60 to 70
2244	Ø22.2	Rate of decrease capacity	92 to 91%	91 to 89%	89 to 87%	87 to 86%	86 to 84%	84 to 81%	81 to 79%
2804									

10 Line up

Combination pattern

Digital inverter 8/10HP				8HP	10HP
				RAV-SM2244AT8(Z,ZG)-E	RAV-SM2804AT8(Z,ZG)-E
				RAV-SM2244AT7(Z,ZG)	RAV-SM2804AT7(Z,ZG)
					
Twin system	4-way cassette		series 4	RAV-SM1104UT-Ex2	RAV-SM1404UT-Ex2
			series 3	NG	NG
			series 2	NG	NG
	Duct		series 2	RAV-SM1102BT-Ex2	RAV-SM1402BT-Ex2
	Ceiling		series 2	RAV-SM1102CT-Ex2	RAV-SM1402CT-Ex2
	Triple system	4-way cassette		series 4	RAV-SM804UT-Ex3
series 3				NG	NG
series 2				NG	NG
Duct			series 2	RAV-SM802BT-Ex3	RAV-SM802BT-Ex3
Ceiling			series 2	RAV-SM802CT-Ex3	RAV-SM804UT-Ex3
High wall			series 2	RAV-SM802KRT-Ex3	RAV-SM802KRT-Ex3
Double twin system	4-way cassette		series 4	RAV-SM564UT-Ex4	RAV-SM804UT-Ex4
			series 3	NG	NG
			series 2	NG	NG
	Compact 4-way cassette		series 2	RAV-SM562MUT-Ex4	-
	Slim duct		series 4	RAV-SM564SDT-Ex4	-
	Duct		series 2	RAV-SM562BT-Ex4	RAV-SM802BT-Ex4
	Ceiling		series 2	RAV-SM562CT-Ex4	RAV-SM802CT-Ex4
	High wall		series 2	RAV-SM562KRT-Ex4	RAV-SM802KRT-Ex4

Branch kit

"1:2" Branch kit	RBC-TWP101E
"1:3" Branch kit	RBC-TRP100E
"1:4" Branch kit set	RBC-DTWP101E

Option parts of outdoor unit

Optional connector cable	TCB-KBOS1E
--------------------------	------------

11 Existing Piping

Work instructions

The existing R22 and R407C piping can be reused for our digital inverter R410A product installations.

WARNING

Confirming the existence of scratches or dents on the existing pipes and confirming the reliability of the pipe strength are conventionally referred to the local site.

Basic conditions needed to reuse existing pipes

Check and observe the presence of three conditions in the refrigerant piping works.

1. **Dry** (There is no moisture inside of the pipes.)
2. **Clean** (There is no dust inside of the pipes.)
3. **Tight** (There are no refrigerant leaks.)

Restrictions for use of existing pipes

In the following cases, the existing pipes should not be reused as they are. Clean the existing pipes or exchange them with new pipes.

1. When a scratch or dent is heavy, be sure to use new pipes for the refrigerant piping works.
2. When the existing pipe thickness is thinner than the specified "Pipe diameter and thickness," be sure to use new pipes for the refrigerant piping works.
 - The operating pressure of R410A is high (1.6 times that of R22 and R407C). If there is a scratch or dent on the pipe or a thinner pipe is used, the pressure strength may be inadequate, which may cause the pipe to break in the worst case.

* Pipe diameter and thickness (mm)

Reference outside diameter (mm)	Wall thickness (mm)	Material
12.7	0.8	—
15.9	1.0	—
22.2	1.0	Half hard
28.6	1.0	Half hard

3. When the outdoor unit was left with the pipes disconnected, or the gas leaked from the pipes and the pipes were not repaired and refilled.
 - There is the possibility of rain water or air, including moisture, entering the pipe.
4. When refrigerant cannot be recovered
 - There is the possibility that a large quantity of dirty oil or moisture remains inside the pipes.
5. When a commercially available dryer is attached to the existing pipes
 - There is the possibility that copper green rust has been generated.

6. When the existing air conditioner is removed after refrigerant has been recovered.
 - Check if the oil is judged to be clearly different from normal oil.
 - The refrigerator oil is copper rust green in color:
 - There is the possibility that moisture has mixed with the oil and rust has been generated inside the pipe.
 - There is discolored oil, a large quantity of residue, or a bad smell.
 - A large quantity of shiny metal dust or other wear residue can be seen in the refrigerant oil.
7. When the air conditioner has a history of the compressor failing and being replaced.
 - When discolored oil, a large quantity of residue, shiny metal dust, or other wear residue or mixture of foreign matter is observed, trouble will occur.
8. When temporary installation and removal of the air conditioner are repeated such as when leased etc.
9. If the type of refrigerator oil of the existing air conditioner is other than the following oil (Mineral oil), Suniso, Freol-S, MS (Synthetic oil), alkyl benzene (HAB, Barrel-freeze), ester series, PVE only of ether series.
 - The winding-insulation of the compressor may deteriorate.

NOTE

The above descriptions are results have been confirmed by our company and represent our views on our air conditioners, but do not guarantee the use of the existing pipes of air conditioners that have adopted R410A in other companies.

Branching pipe for simultaneous operation system

- In the concurrent twin system, when TOSHIBA has specified that branching pipe is to be used, it can be reused.
 - Branching pipe model name:
RBC-TWP30E2, RBC-TWP50E2, RBC-TRP100E
 - On the existing air conditioner for simultaneous operation system (twin, triple, double twin system), there are cases of branch pipes being used that have insufficient compressive strength.
 - In such case, please change the piping to a branch pipe for R410A.

Curing of pipes

When removing and opening the indoor or outdoor unit for a long time, cure the pipes as follows:

- Otherwise rust may be generated when moisture or foreign matter due to condensation enters the pipes.
- The rust cannot be removed by cleaning, and new pipes are necessary.

Placement location	Term	Curing manner
Outdoors	1 month or more	Pinching
	Less than 1 month	Pinching or taping
Indoors	Every time	

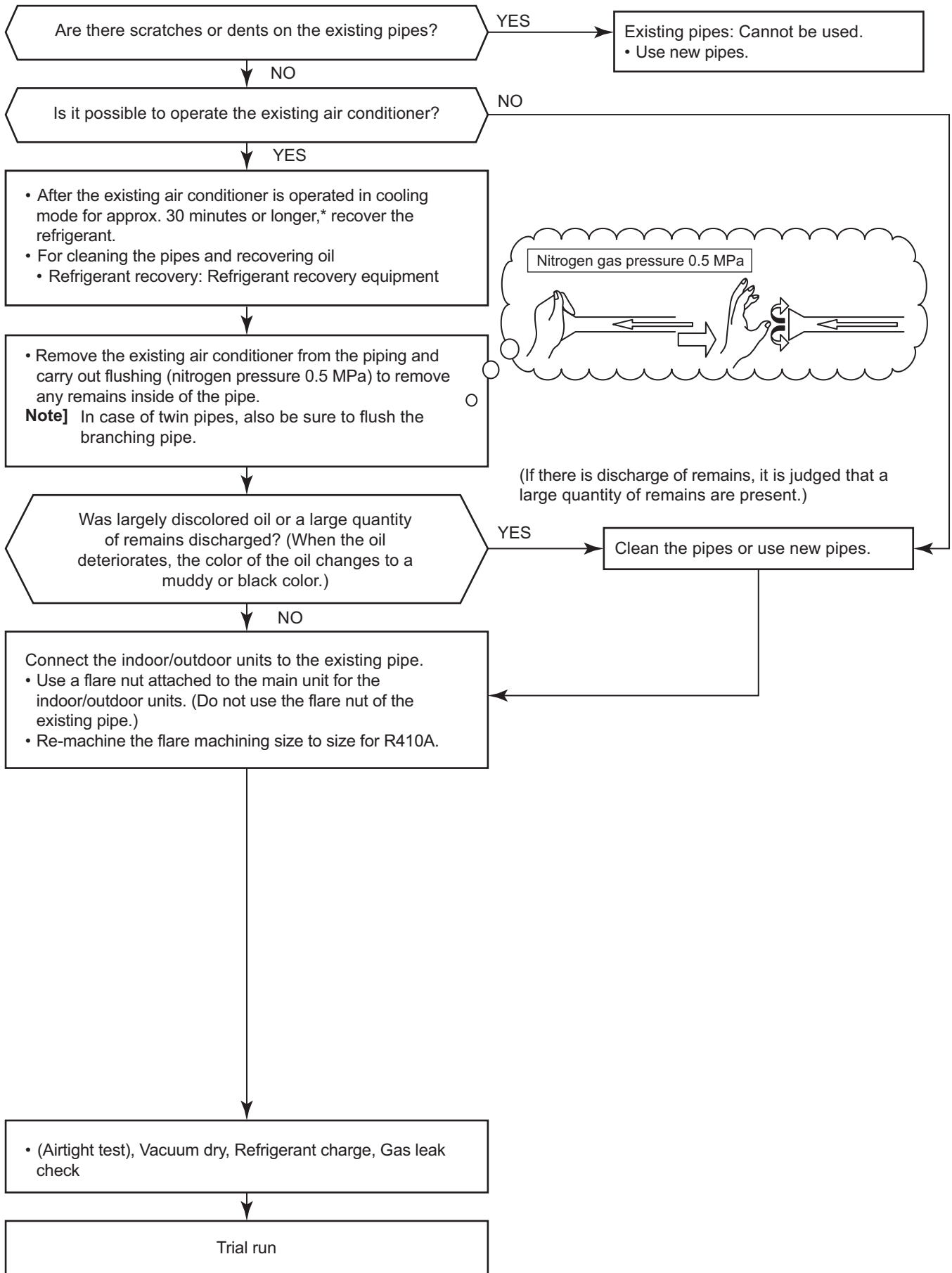

TOSHIBA AIR CONDITIONING

Advancing the **eco**-evolution

**Digital Inverter 4series 8-10HP
Engineering Data Book**

TOSHIBA CARRIER CORPORATION

Jul. 2009